

B400 ^{XP-2}

HYDRAULIC PILING RIG
ATTREZZATURA IDRAULICA PER PALI



casagrande

TECHNICAL INFORMATION

The Casagrande B400XP-2 is a multifunctional hydraulic piling rig for foundation construction by drilling boreholes in rotary piling, Large Diameter Piling (LDP), to insert and extract casings, to power a casing oscillator, for piling by the continuous flight auger method (CFA) and CFA Rapid, displacement piles (DP), soil mixing and for conversion to diaphragm wall equipment KRC Grab and KHD Grab.

Designed and built using the latest state of the of art technology. A machine engineered for the most demanding conditions with particular emphasis on performance efficiency, reliability and economy.

INFORMAZIONI TECNICHE

La Casagrande B400XP-2 è un'attrezzatura idraulica multifunzionale per lavori di fondazioni mediante la perforazione di fori con rotary, palificazione di grande diametro (LDP), per l'inserimento e l'estrazione di tubi colonna, per l'alimentazione di morsa giracolonna, per perforazioni con elica continua (CFA), displacement piles (DP), soil mixing e per diaframmi con benna KRC e KHD.

Progettata e costruita utilizzando le più recenti tecnologie.

Una macchina ingegnerizzata per le condizioni di lavoro più impegnative, con particolare attenzione all'efficienza delle prestazioni, all'affidabilità e ai consumi.

1 H47 HYDRAULIC ROTARY HEAD

Powerful hydraulic rotary head with torque of 467 kNm

2 MAIN AND AUXILIARY WINCHES

Fast and powerful with controlled fall with line pull of 375 kN and 150 kN

3 MAST SUPPORT WITH STURDY STRUCTURE

4 OPERATOR'S CABIN

Comfortable and ergonomic cabin with 12" monitor

5 POWERFUL DIESEL ENGINE

Power 450 kW

6 HEAVY DUTY AND MODULAR MAST

Equipped with crowd ram or winch pull down system

7 HD KELLY BARS

Friction or interlocking type for drilling depth up to 99 m

8 HD UNDERCARRIAGE

1000 mm extendable triple grouser track shoes

9 MODULAR COUNTERWEIGHT

Weight according to the arrangement, easy assembly and transport

1 ROTARY IDRAULICA H47

Potente rotary idraulica con coppia di 467 kNm

2 ARGANI PRINCIPALE E AUSILIARIO

Veloci e potenti a discesa controllata con tiro 375 kN e 150 kN

3 ROBUSTO PANTOGRAFO PER SUPPORTO MAST

4 CABINA OPERATORE

Cabina confortevole ed ergonomica con monitor da 12"

5 POTENTE MOTORE DIESEL

Potenza di 450 kW

6 MAST RINFORZATO MODULARE

Equipaggiato con argano o cilindro pull down

7 ASTE TELESCOPICHE HD

A frizione o bloccaggio per scavi fino a 99 m

8 SOTTOCARRO RINFORZATO

Cingoli estendibili con pattini a tre barre da 1000 mm

9 ZAVORRA MODULARE

Peso scelto in base all'attrezzatura montata, semplici fasi di montaggio e trasporto

B400^{XP2}

PERFORMANCE - PRESTAZIONI



4500 mm

Max. drilling diameter / Diametro max.



99 m

Drilling depth / Profondità di perforazione



467 kNm

Torque / Coppia



450 kW

Diesel engine power / Potenza motore



124 t

Operating weight / Peso attrezzatura

Maximum values vary according to the set-up
I valori massimali variano in funzione dell'allestimento



PERFORMANCE

PRESTAZIONI

BORED PILES	PALI	
Max. depth	Profondità max.	99 m
Max. diameter under mast	Diametro max. sotto mast	4500 mm
Max. diameter - Labyrinth / Screw joint - Crowd ram	Diametro max. - Giunto labirinto/vite - Martinetto pull down	2700/2400 mm
Max. diameter - Labyrinth / Screw joint - Crowd winch	Diametro max. - Giunto labirinto/vite - Argano pull down	2300/2000 mm
Max. diameter with casing oscillator	Diametro max. morsa giracolonna	2000 mm
CFA PILES	PALI CFA	
Max. depth	Profondità max.	37 m
Max. diameter	Diametro max.	1200 mm
CASED CFA PILES	PALI CFA INTUBATI	
Max. depth	Profondità max.	18,5 m
Max. diameter	Diametro max.	1000 mm
DISPLACEMENT PILES	DISPLACEMENT PILES	
Max. depth	Profondità max.	30 m
Max. diameter	Diametro max.	620 mm
SOIL MIXING	SOIL MIXING	
Max. depth	Profondità max.	33,5 m
Max. diameter	Diametro max.	1500 mm
CUTTER SOIL MIXING	CUTTER SOIL MIXING	
Depth	Profondità	23,3 m
DIAPHRAGM WALL	DIAFRAMMI	
Max. depth with KRC	Profondità max. con KRC	45 m
Max. depth with KHD	Profondità max. con KHD	80 m





TECHNICAL SPECIFICATIONS

DATI TECNICI

MAIN WINCH	ARGANO PRINCIPALE	
Line pull on 1 st layer nominal / effective	Tiro sul 1° strato nominale / effettivo	375 / 300 kN
Max. line speed	Velocità max.	82 m/min
Rope diameter	Diametro fune	32 mm
OPTION MAIN WINCH	OPZIONE ARGANO PRINCIPALE	
Line pull on 1 st layer nominal / effective	Tiro sul 1° strato nominale / effettivo	435 / 350 kN
Max. line speed	Velocità max.	79 m/min
Rope diameter	Diametro fune	36 mm
AUXILIARY WINCH	ARGANO AUSILIARIO	
Line pull on 1 st layer nominal / effective	Tiro sul 1° strato nominale / effettivo	150 / 120 kN
Max. line speed	Velocità max.	67 m/min
Rope diameter	Diametro fune	24 mm
CROWD RAM	MARTINETTO PULL DOWN	
Extraction / Crowd force	Forza di Estrazione / Spinta	400 / 250 kN
Extraction / Crowd speed	Velocità di Estrazione / Spinta	13 / 25 m/min
Stroke	Corsa	7 m
CROWD WINCH	ARGANO PULL DOWN	
Extraction / Crowd force nominal	Forza di Estrazione / Spinta nominale	690 / 690 kN
Extraction / Crowd force effective	Forza di Estrazione / Spinta effettiva	550 / 550 kN
Extraction force on casing drive adapter	Forza di Estrazione / Spinta effettiva	450 kN
Extraction / Crowd speed	Forza di Estrazione al trascinatore	38 / 38 m/min
Stroke max.	Corsa max.	21 m

ROTARY HEADS

TESTE ROTARY

ROTARY HEAD	ROTARY IDRAULICA	H47
Max. nominal torque	Coppia max. nominale	467 kNm
Max. drilling speed	Velocità max. di scavo	50 rpm
Discharge speed	Velocità di scarico	Rotary shaking

ROTARY HEAD	ROTARY IDRAULICA	H30 SX
Max. nominal torque	Coppia max. nominale	220 kNm
Max. drilling speed	Velocità max. di scavo	90 rpm
Discharge speed	Velocità di scarico	100 rpm

H47 ROTARY HEAD ROTARY H47

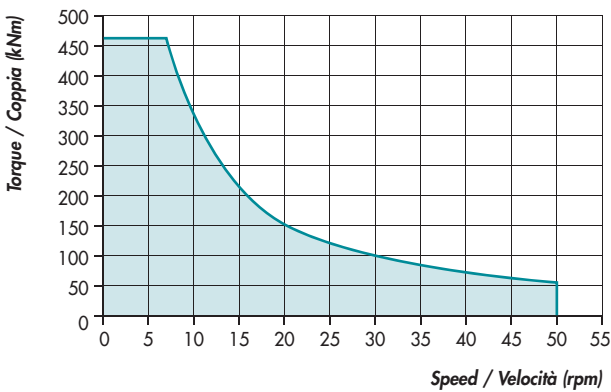

H30SX ROTARY HEAD ROTARY H30SX

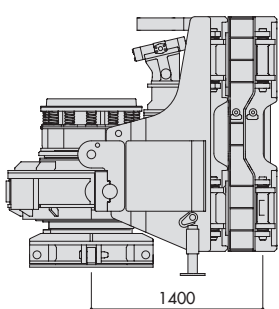
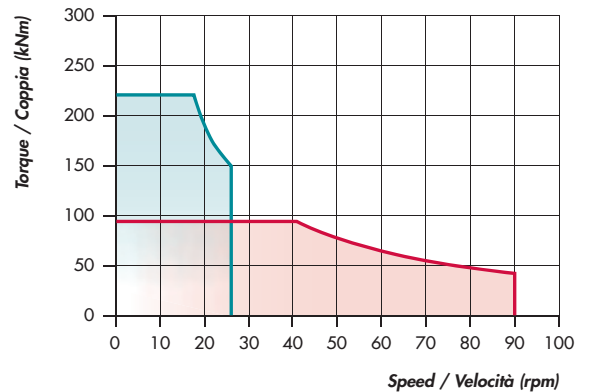

Drilling axis
Interasse

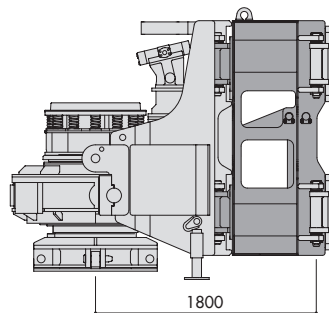

Drilling axis extension
Slitta supplementare

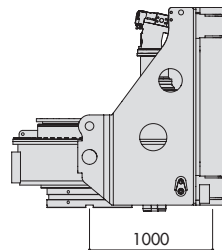

Soil mixing application
Applicazione soil mixing

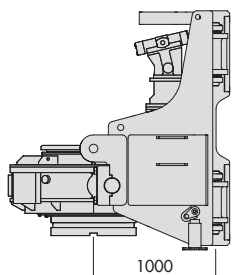

CFA application
Applicazione CFA

TECHNICAL SPECIFICATIONS

DATI TECNICI

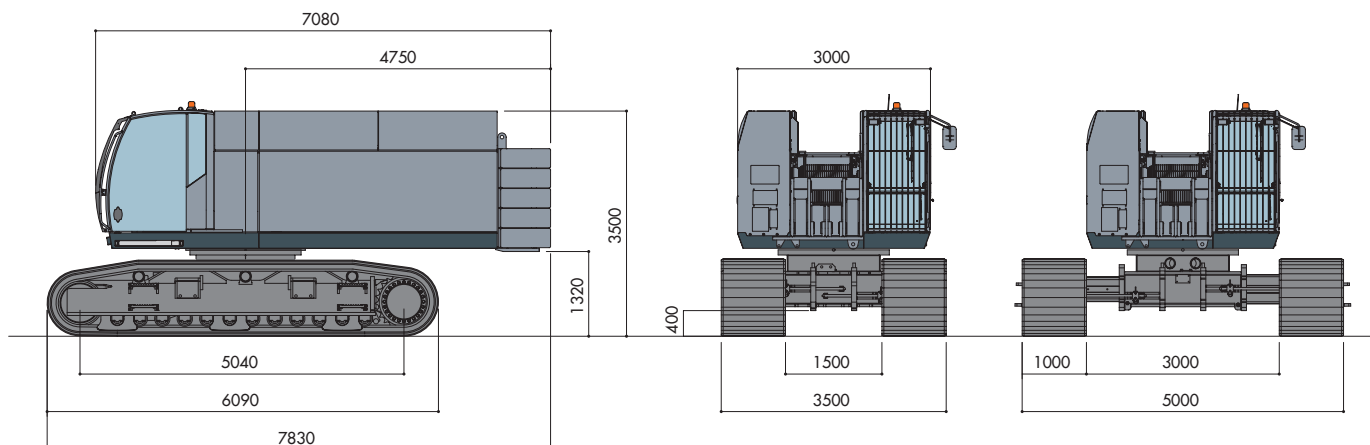

BASE CARRIER	CARRO BASE	
Diesel engine Stage V - Tier 4	Motore diesel Stage V - Tier 4	CUMMINS X15
Power @ 1800 rpm	Potenza @ 1800 rpm	450 kW
Diesel tank capacity	Capacità serbatoio gasolio	720 l
Urea tank capacity	Capacità serbatoio urea	57 l
* Diesel engine Stage IIIA - Tier 3 equivalent	* Motore diesel Stage IIIA - Tier 3 equivalente	CUMMINS QSX-15
Power @ 1800 rpm	Potenza @ 1800 rpm	441 kW
HYDRAULIC SYSTEM	IMPIANTO IDRAULICO	
Hydraulic power	Potenza idraulica	405 kW
Hydraulic pressure	Pressione idraulica	350 bar
Main pumps flow rate	Pompe principali portata	405 + 405 + 309 l/min
Hydraulic oil tank capacity	Capacità serbatoio olio idraulico	1000 l
UNDERCARRIAGE	SOTTOCARRO	D7F
Undercarriage width with retracted / extended tracks	Larghezza sottocarro con cingoli chiusi / aperti	3500 / 5000 mm
Width of triple grouser track shoes	Larghezza pattini a tre barre	1000 mm
Overall tracks length	Lunghezza cingoli	6090 mm
Travel speed	Velocità traslazione	0 ÷ 1 km/h
Traction force - Nominal / Effective	Forza di trazione - Nominale / Effettiva	860 / 690 kN
Weight of basic machine without attachment	Peso macchina base senza attrezzatura	~ 74000 kg

* Optional



BORED PILING

ALLESTIMENTO PER PALI

PILING ARRANGEMENT WITH CROWD RAM ALLESTIMENTO PALI CON MARTINETTO PULL DOWN

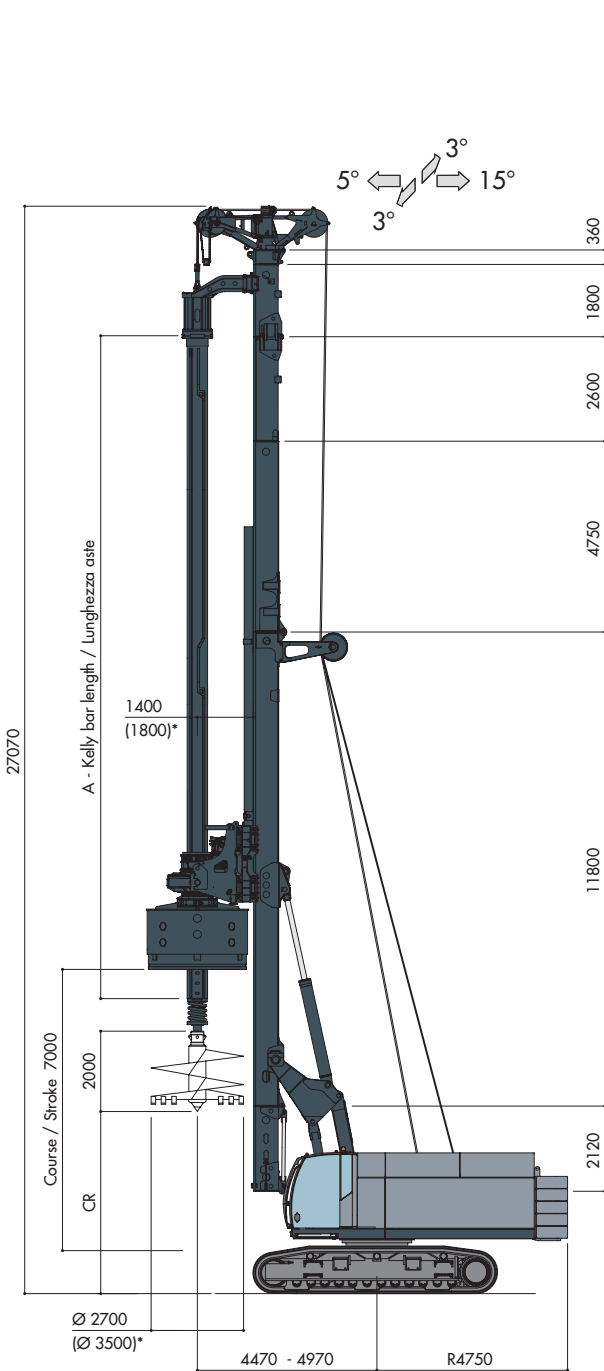

* Optional

Operating weight with kelly bar I 4x14500
Peso attrezzatura con aste I 4x14500
~ 124000 kg

PILING ARRANGEMENT WITH CROWD WINCH ALLESTIMENTO PALI CON ARGANO PULL DOWN

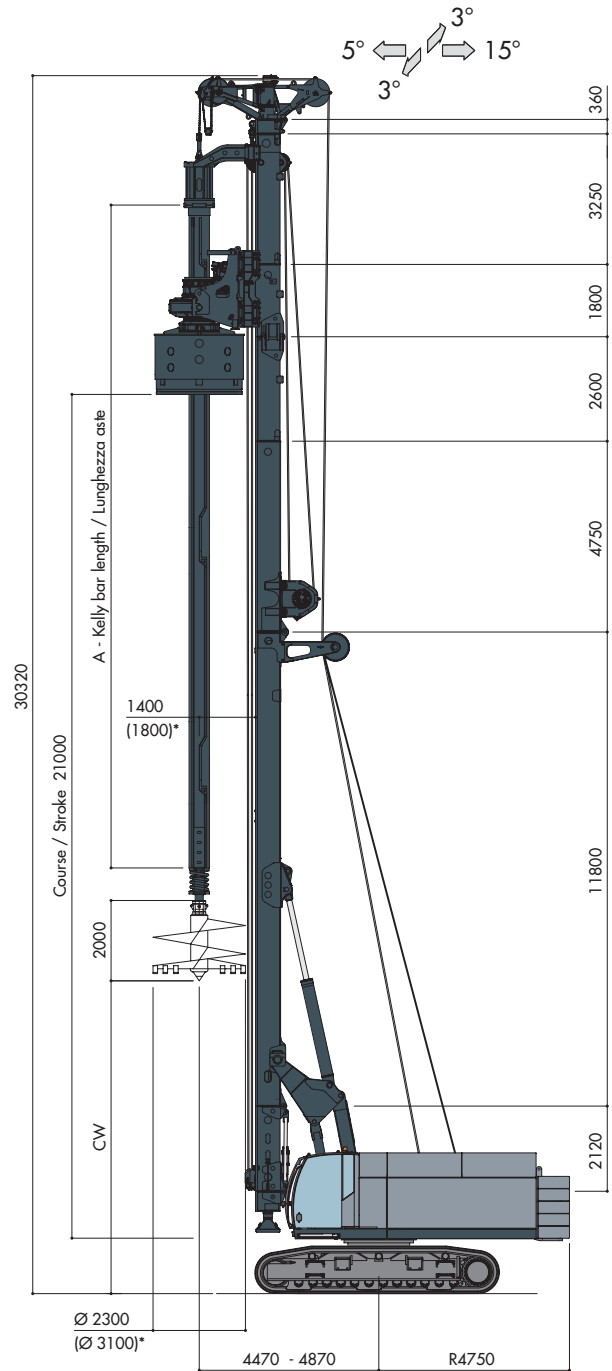

* Optional

Operating weight with kelly bar I 4x14500
Peso attrezzatura con aste I 4x14500
~ 128000 kg

KELLY BARS SPECIFICATIONS

DATI TECNICI ASTE TELESCOPICHE

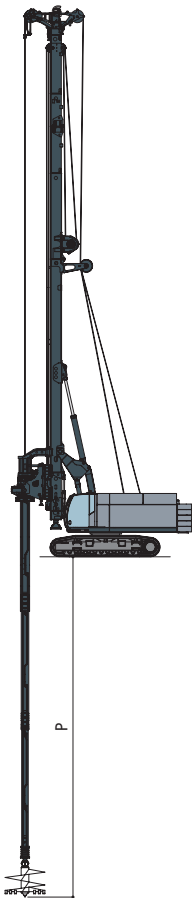

I = interlocking F = friction	nominal diameter	number of elements	max. torque	nominal length	CROWD RAM		CROWD WINCH		weight type I (kg)
					drilling depth	max. ground clearance	drilling depth	max. ground clearance	
type	(mm)	n°	(kNm)	A	P (m)	CR (m)	P (m)	CW (m)	
I	508	3	500	11000	29,3	6,8	28,9	13,2	9715
I	508	3	500	12500	33,8	6,8	33,4	11,7	10740
I	508	3	500	14500	39,8	6,5	39,4	9,7	12125
I	508	3	500	16500	45,8	4,5	45,5	7,7	13495
I	508	3	500	19000	53,3 *	4,9 *	52,9	5,2	15275
I	508	3	500	21000	59,3 *	2,9 *	58,9	3,2	16660
I-F	508	4	480	11000	39,3	6,8	38,9	13,2	10530
I-F	508	4	480	12500	45,3	6,8	44,9	11,7	11700
I-F	508	4	480	14500	53,3	6,5	52,9	9,7	13280
I-F	508	4	480	16500	61,3	4,5	60,9	7,7	14850
I-F	508	4	480	19000	71,3 *	4,9 *	70,9	5,2	16865
I-F	508	4	480	21000	79,3 *	2,9 *	78,9	3,2	18435
F	508	5	300	11000	49,3	6,8	48,9	13,2	11350
F	508	5	300	12500	56,8	6,8	56,4	11,7	12575
F	508	5	300	14500	66,8	6,5	66,4	9,7	14200
F	508	5	300	16500	76,8	4,5	76,4	7,7	15835
F	508	5	300	19000	89,3 *	4,9 *	88,9	5,2	17720
F	508	5	300	21000	99,3 *	2,9 *	98,9	3,2	19345

Data refer to depicted arrangement
Valori riferiti agli allestimenti illustrati

* To be used with 3,25 m additional mast extension
Per l'uso necessaria prolunga aggiuntiva mast di 3,25 m

ARRANGEMENT WITH CASING OSCILLATOR

ALLESTIMENTO PALI CON MORSA GIRACOLONNA

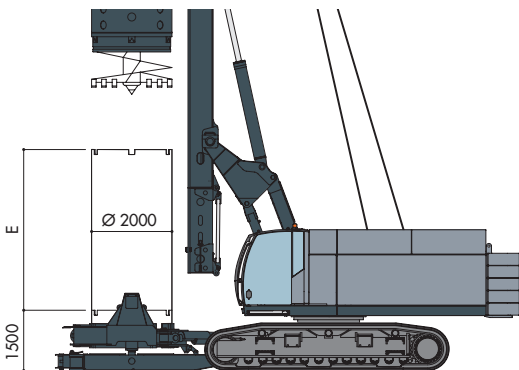

Piling arrangement with crowd ram
Allestimento pali con martinetto pull down

A	11000	12500	14500
E	5000	4000	2000
Length of casing without oscillator Lunghezza tubo senza morsa	5000	3000	2000

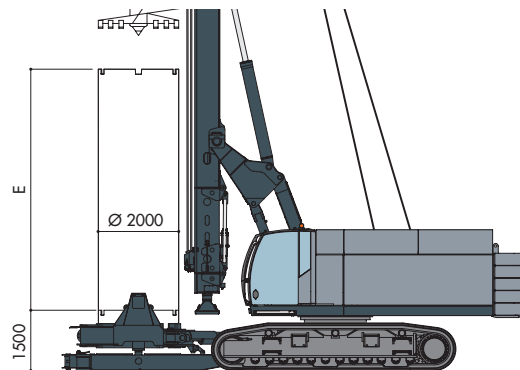

Piling arrangement with crowd winch
Allestimento pali con argano pull down

A	12500	14500	16500	19000
E	9000	7000	5000	3000
Length of casing without oscillator Lunghezza tubo senza morsa	9000	7000	5000	3000

CFA BORED PILING

ALLESTIMENTO PALI CFA

RAPID VERSION VERSIONE RAPIDA

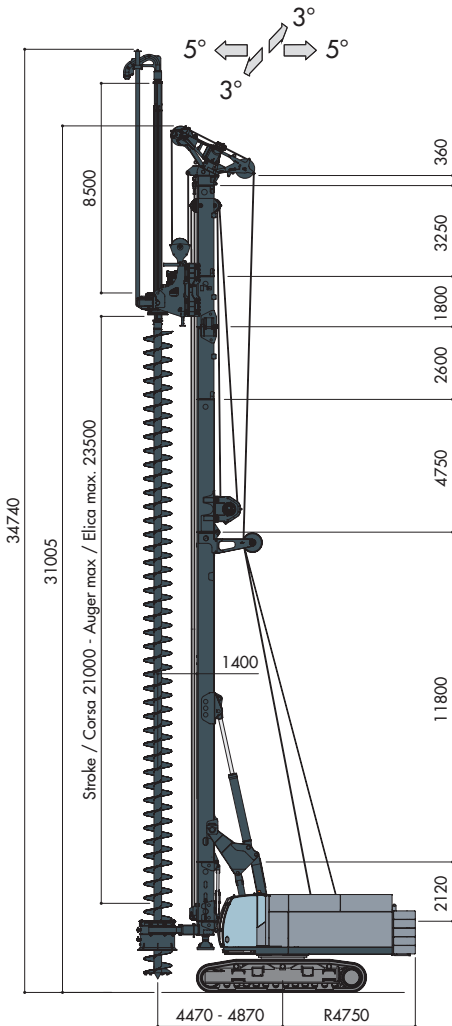

STANDARD VERSION VERSIONE STANDARD

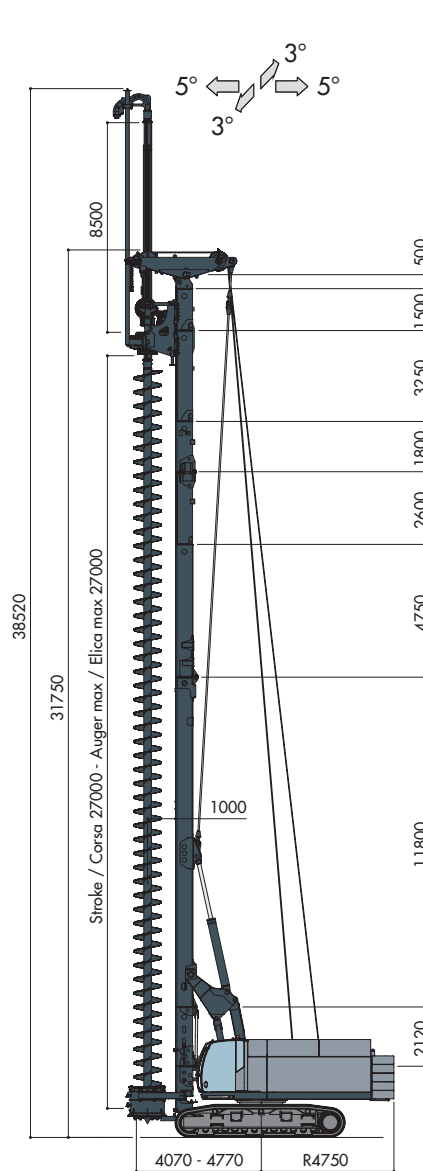

EXTENDED VERSION VERSIONE LUNGA

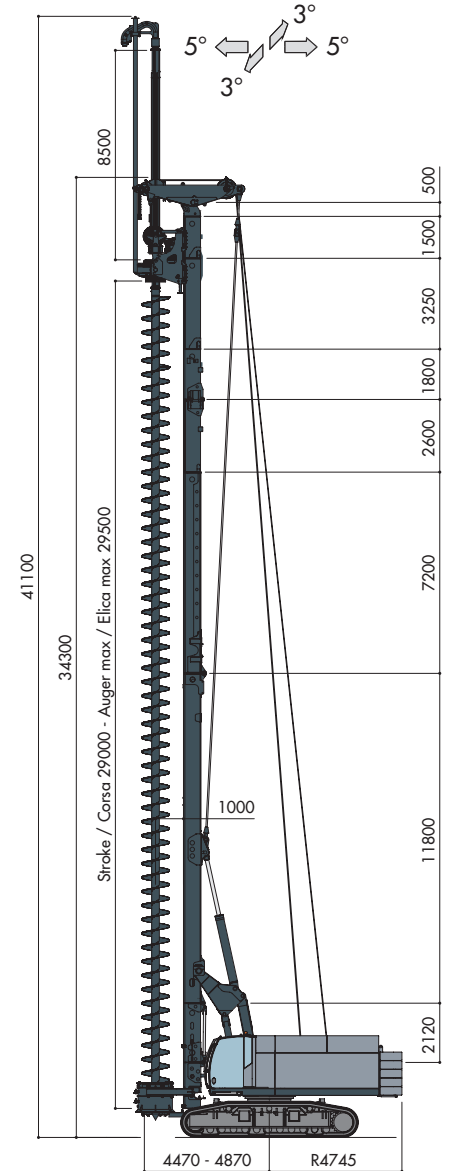

DRILLING DATA	DATI DI SCAVO	RAPID	STANDARD	EXTENDED*
Max. diameter	Diametro max.	1200 mm	1200 mm	1200 mm
Max. depth with star auger cleaner	Profondità max. con pulisci elica stellare	29 m	35 m	37 m
Max. depth with rotating auger cleaner	Profondità max. con pulisci elica rotante	27,9 m	33,9 m	35,9 m
Extraction force Nominal / Effective	Forza di Estrazione Nominale / Effettiva	1050 / 840 kN	1245 / 1000 kN	1245 / 1000 kN
Crowd force Nominal / Effective	Spinta Nominale / Effettiva	690 / 550 kN	136 / 110 kN (opt.)	136 / 110 kN (opt.)
Weight w/o auger	Peso senza elica	~116000 kg	~109000 kg	~117000 kg

Data refer to depicted arrangement
Depth reduced by 1 m with crowd force option

Valori riferiti agli allestimenti illustrati
Profondità ridotta di 1 m con opzione sistema spinta

* With special undercarriage
Con sottocarro speciale



TRANSPORT DATA

DATI DI TRASPORTO

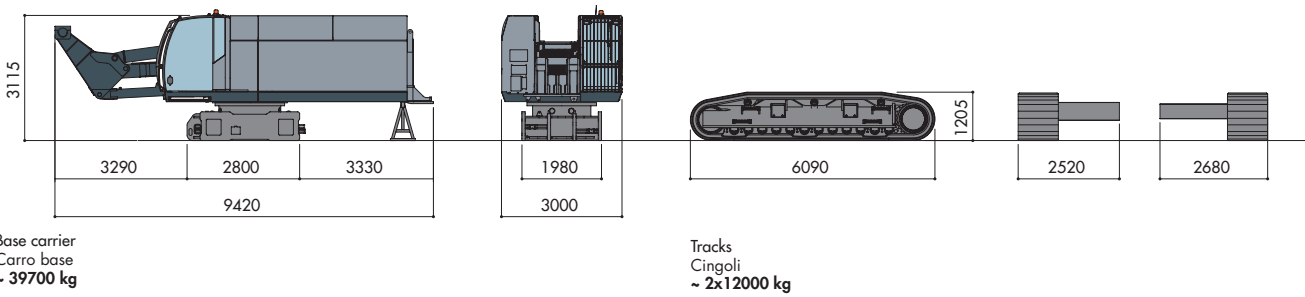
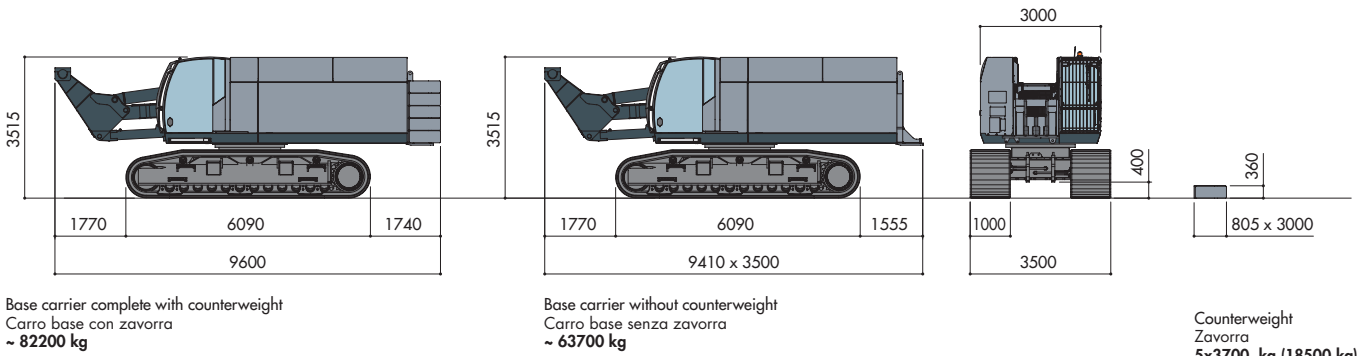

CROWD RAM ARRANGEMENT
ALLESTIMENTO CON MARTINETTO PULL DOWN

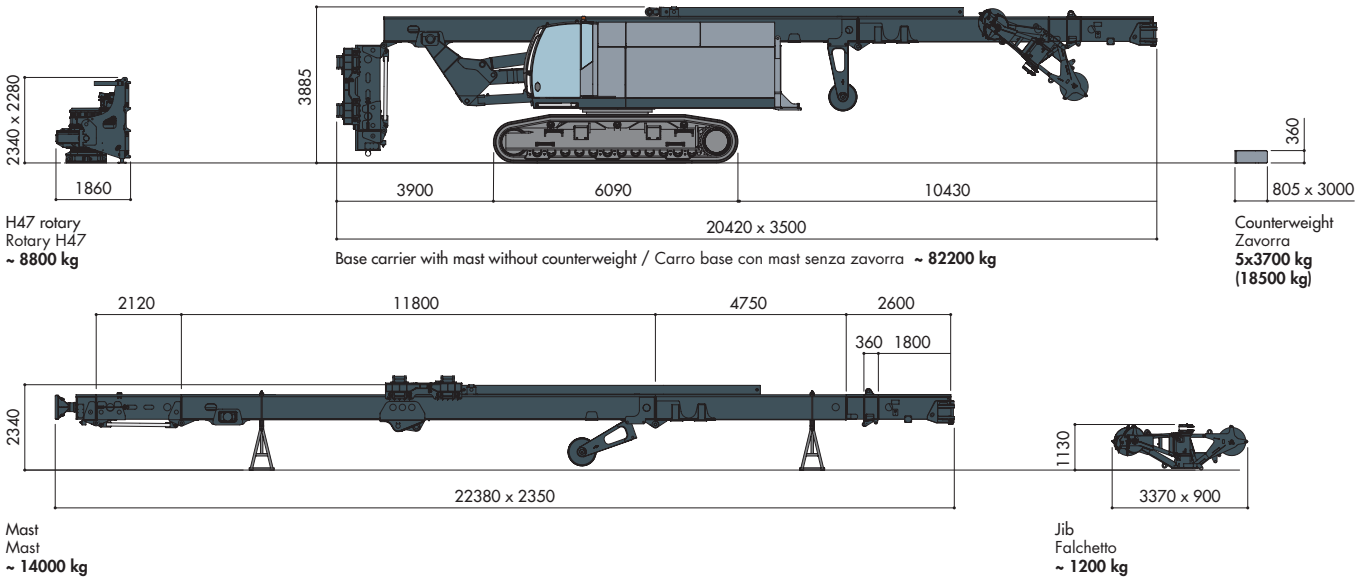

CROWD WINCH ARRANGEMENT
ALLESTIMENTO CON ARGANO PULL DOWN

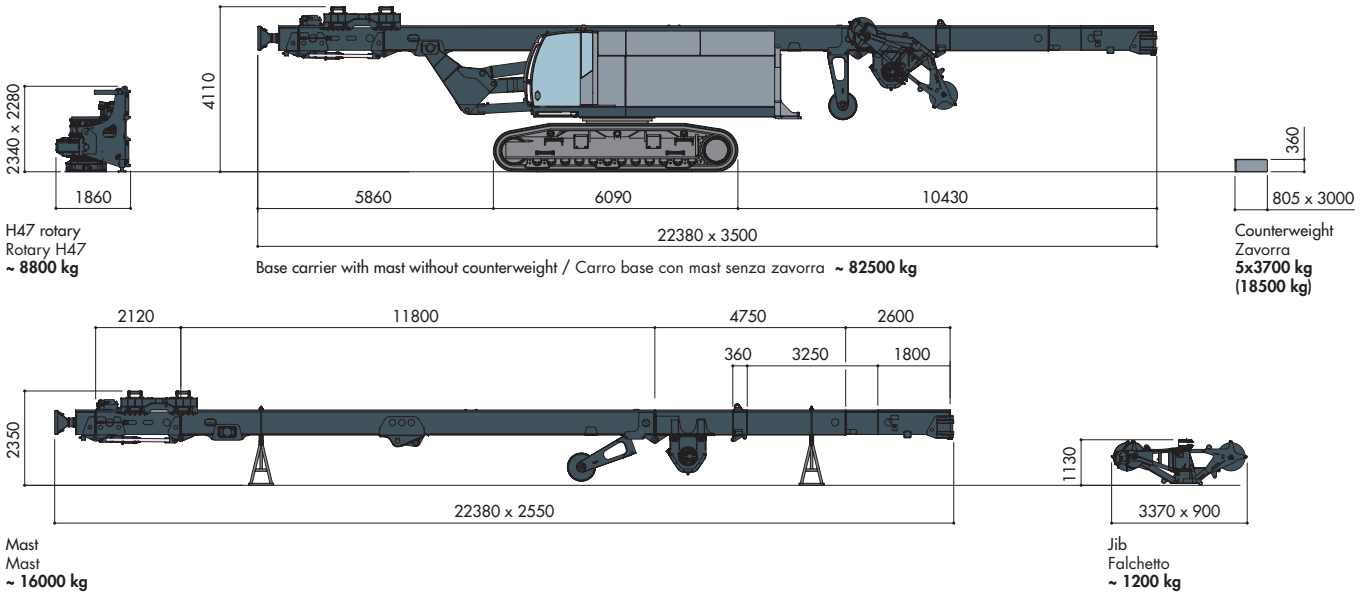

C.F.A. PILING ARRANGEMENT
ALLESTIMENTO PER VERSIONE C.F.A.

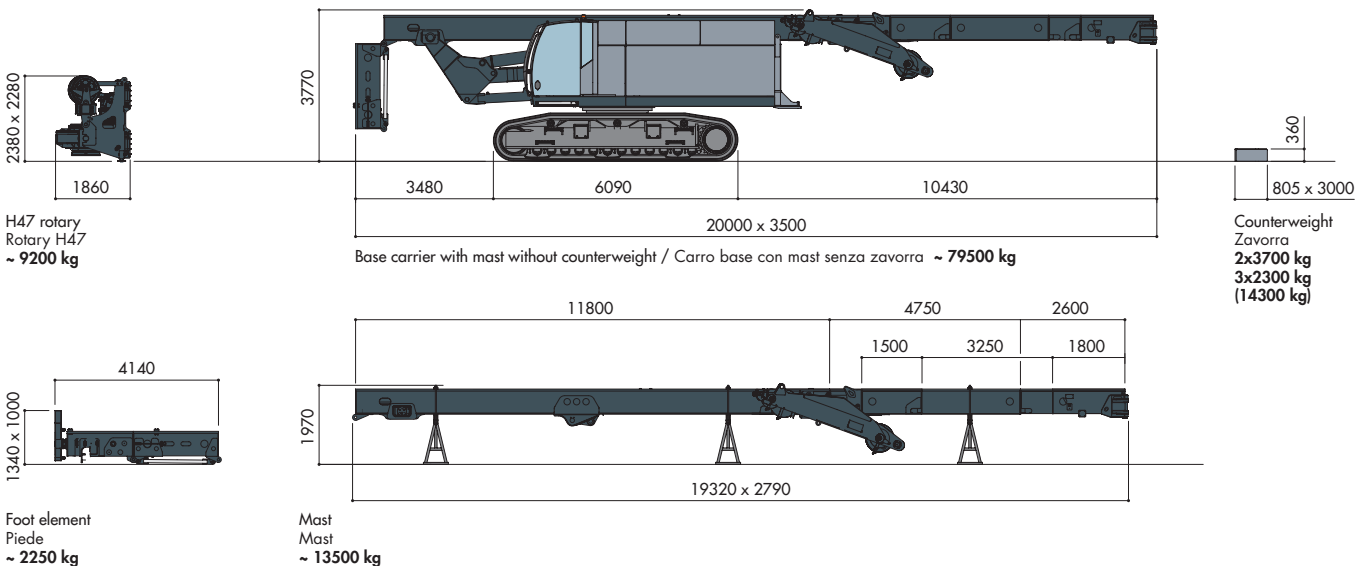

STANDARD EQUIPMENT

DISPOSITIVI DI SERIE

BASIC MACHINE

SPM control system - Smart Power Management

12" touch screen display for visualization and setting of drilling parameters

Mast lifting and lowering aid

Drilling depth measurement and automatic mast verticality control

Automatic idling mode with engine start/stop for fuel saving

Rotary shaking system for tool discharge

Hook on auxiliary line

Protective roof guard (FOPS compliant)

Air condition system

Cab front and side catwalk

Electric refueling pump

MACCHINA BASE

Sistema SPM di controllo e gestione della potenza

Monitor touch-screen da 12" per visualizzazione e settaggio dei parametri di lavoro

Sistema di sollevamento e abbassamento automatico del mast

Misura profondità perforazione e controllo automatico verticalità mast

Auto-idling del motore diesel per risparmio di carburante

Sistema "rotary shaking" per scarico utensile di perforazione

Gancio sulla fune dell'argano ausiliario

Protezione FOPS su cabina operatore

Aria condizionata in cabina operatore

Pedana anteriore e laterale sulla cabina operatore

Pompa elettrica per riempimento gasolio



OPTIONAL EQUIPMENT

DISPOSITIVI OPZIONALI

BASIC MACHINE

Lateral catwalks and handrails

Railings on upper structure

Water pre-heating system for starting engine at low temperatures

Automatic centralized greasing system

Radio remote control for rigging, derigging, tracking and positioning

Video unit with two cameras and one 7" monitor to control winches and the rear of the machine

Camera for panoramic view of the area around the machine

Automatic self-alignment on drilling axis

Casagrande FleetMaster remote rig control and monitoring via internet

Transport kit according to required transport configuration

MACCHINA BASE

Pedane laterali e ringhiere anticaduta

Ringhiere anticaduta sulla parte superiore del carro

Sistema di preriscaldamento acqua motore per accensione a bassa temperatura

Sistema automatico di ingrassaggio centralizzato

Radiocomando per montaggio, smontaggio, traslazione e posizionamento

Telecamere di controllo e monitor da 7" in cabina per sorvegliare argani e zona posteriore macchina

Telecamera per visualizzazione panoramica area intorno alla macchina

Sistema di ritorno automatico in asse di perforazione

Casagrande FleetMaster monitoraggio e controllo delle macchine via internet

Kit di trasporto in funzione della modalità di trasporto



ROTARY PILING EQUIPMENT

Drilling axis extension to increase the drilling diameter

Mast extensions for extended mast version

Low headroom arrangement

Cardanic joint for rotary head

Main controlled winch 435 kN nominal line pull

Main free fall winch 315 kN nominal line pull

Smart lowering and overload protection for main winch

Load cell on auxiliary winch for line pull monitoring

Pull control and overload protection for pull-down winch

Hydraulic mast folding for transport

Hydraulic jib folding for transport

Arrangement for casing oscillator

Casing oscillator GCL 1500 / GCL 2000

CFA EQUIPMENT

Measurement and visualization of extraction force

Rotating CFA cleaner hydraulically operated

Star CFA cleaner

CFA lower guide with hydraulic opening

Crowd winches for CFA. Max nominal crowd force 2x68 kN

Hydraulic vibrator for cages

CFA feed control

Instrument for measuring, displaying and recording of drilling parameters. Complete with software for processing data on a PC

Instrument for continuous extraction of CFA

ALLESTIMENTO PALI

Estensione interasse rotary per incremento diametro di perforazione

Prolunghe mast per versioni speciali

Versione macchina ribassata

Giunto cardanico per testa di perforazione

Argano principale a caduta controllata con tiro nominale di 435 kN

Argano principale a caduta libera con tiro nominale di 315 kN

Smart lowering e protezione sovraccarichi su argano principale

Cella di carico sull'argano ausiliario per controllo del carico sollevato

Sistema regolazione spinta e protezione al sovraccarico argano pull down

Ripiegamento idraulico del mast per trasporto

Ripiegamento idraulico del falchetto per trasporto

Predisposizione per morsa giracolonna

Morsa giracolonna GCL 1500 / GCL 2000

ALLESTIMENTO CFA

Misurazione e visualizzazione della forza di estrazione

Pulitore elica rotante comandato idraulicamente

Pulitore elica a stella

Centratore elica con apertura idraulica

Argani pull down per CFA. Forza max. nominale spinta 2x68 kN

Vibratore idraulico per gabbie

Regolazione velocità di avanzamento in CFA

Strumentazione di misura, visualizzazione e registrazione dei parametri di lavoro. Software per post trattamento dati registrati

Strumentazione per estrazione CFA continua

ADDITIONAL APPLICATIONS

APPLICAZIONI COMPLEMENTARI

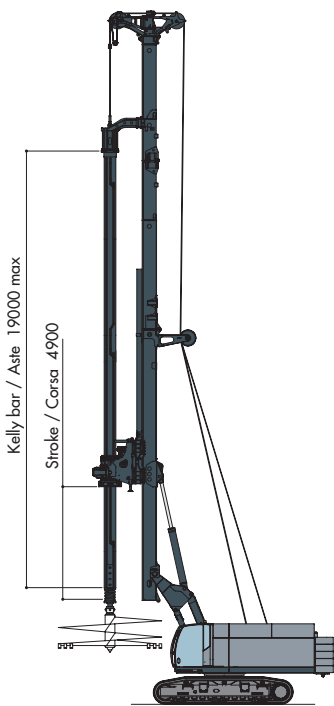

UNDERMAST

Max. depth	Prof. max.	87 m
Diameter	Diametro	4500 mm

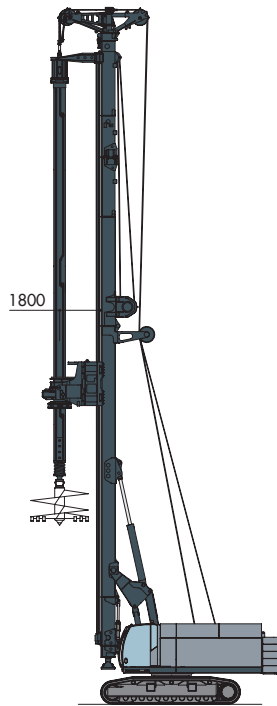

AXIS EXTENSION

Max. depth	Prof. max.	99 m
Diameter	Diametro	3500 mm

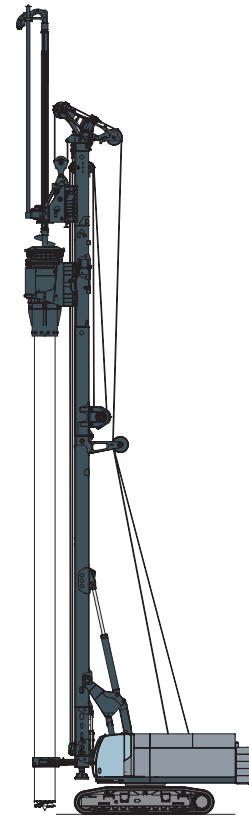

CASED C.F.A. PILES

Max. depth	Prof. max.	27 / 18,5 m
Diameter	Diametro	1000 mm



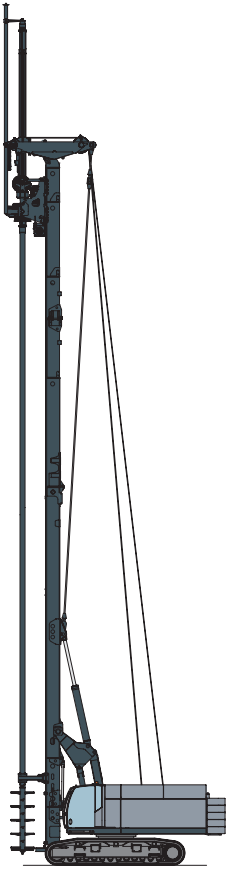

SOIL MIXING

Max. depth	Prof. max.	33,5 m
Diameter	Diametro	1500 mm

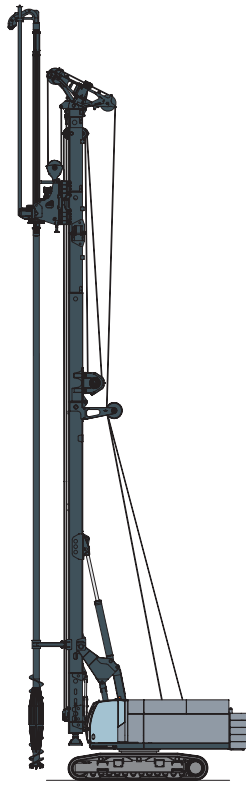

DISPLACEMENT

Max. depth	Prof. max.	28 m
Diameter	Diametro	620 mm

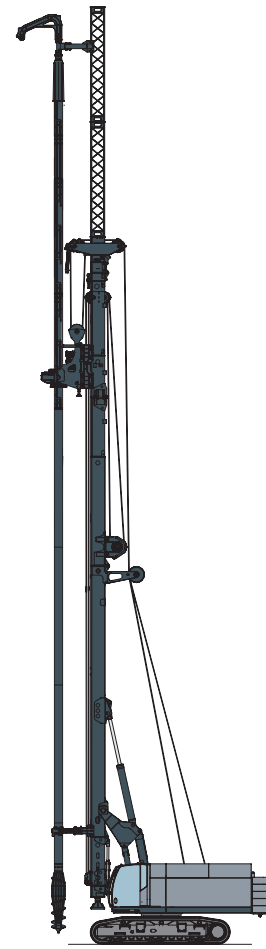

LONG DISPLACEMENT

Max. depth	Prof. max.	32 m
Diameter	Diametro	620 mm

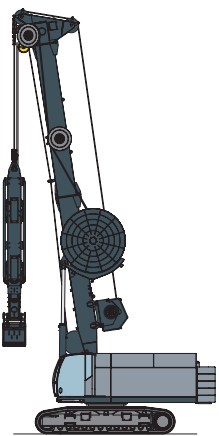

KHD - DIAPHRAGM WALL

Max. depth	Prof. max.	80 m
Trench	Pannello	3200 x 1500 mm



KRC - DIAPHRAGM WALL

Max. depth	Prof. max.	45 m
Trench	Pannello	3000 x 1500 mm



CUTTER SOIL MIXING

Max. depth	Prof. max.	23,3 m
Trench	Pannello	2800 x 1000 mm

EXPERIENCE, PLUS, INNOVATION

ESPERIENZA E INNOVAZIONE



XP-2 SERIES

The XP-2 series use hydraulic and electronic systems that directly control the hydraulic pumps to achieve efficient, precise and rapid results. The specialist components, along with the enhanced hydraulic layout, optimizes efficiency leading to reduced load losses and fuel consumption.

XP-2 SERIE

Gli impianti idraulici delle macchine serie XP-2, sono realizzati per un controllo diretto delle pompe idrauliche e del circuito di potenza, per una efficiente, precisa e rapida esecuzione delle manovre. L'impianto idraulico e i componenti sono ottimizzati per ridurre le perdite di carico e per garantire una maggiore efficienza.



CFM - CASAGRANDE FLEET MASTER

The fleet can be managed remotely via an online platform by PC, tablet or smartphone. This includes remote monitoring of any alarms and immediate diagnostics by the After Sales Service Team leading to significant reductions in intervention costs and rig downtime.

CFM - CASAGRANDE FLEET MASTER

È la piattaforma online che permette di controllare lo stato della flotta macchine da web remoto con PC, tablet o smartphone. Monitoraggio di eventuali allarmi e immediata diagnostica da parte dell'assistenza con riduzione di costi di intervento e tempi di fermo macchina.



ASSISTANCE AND MONITORING

Operators benefit from automation of drilling functions, making the rigs user friendly with complete control of the drilling process. The cab display provides real time drilling data progress including depth, torque, pressure and verticality for operator control.

ASSISTENZA E MONITORAGGIO

Il compito dell'operatore è semplificato grazie alla disponibilità di automatismi che semplificano il lavoro e ottimizzano i risultati. Sistemi di monitoraggio delle funzioni di lavoro forniscono in tempo reale ed efficace all'operatore il controllo delle operazioni.



CDR - CASAGRANDE DATA RECORDER

CDR is available for all disciplines of piling and drilling and allows the rig operator to monitor the drilling progress on screen. Work parameters are recorded for subsequent analysis, or for site reports.

CDR - CASAGRANDE DATA RECORDER

Il CDR è applicabile per le macchine Casagrande ed è disponibile per tutte le tecnologie di lavoro. L'operatore monitora sullo schermo l'andamento del processo e i parametri delle lavorazioni sono registrati per successive analisi o per redazione di report di cantiere.

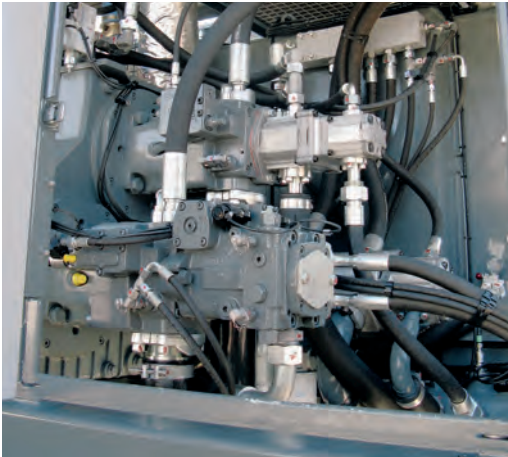

PERFORMANCE AND PRODUCTIVITY

The Smart Power Management (SPM) is an engine power management system that improves performances and productivity of the machinery. SPM monitors the power flows drawn from the engine and allocates the maximum available power to the required function.

PRESTAZIONI E PRODUTTIVITÀ

Il sistema Smart Power Management (SPM) permette una gestione intelligente della potenza del motore, aumentando prestazioni e produttività. Esso monitora i flussi di potenza istantanei e destina in tempo reale la piena potenza disponibile alle funzioni di lavoro.



COMFORT & TECHNOLOGY

The operator cabin is ergonomically designed for user comfort and soundproofing. Smart oil heat exchangers reduce fuel consumption and the overall noise level of the cooling system.

COMFORT & TECHNOLOGY

La postazione operatore raggiunge livelli elevati di ergonomia e comfort attivo e passivo con riduzione del rumore esterno. Scambiatori di calore smart riducono il livello di rumorosità e il consumo di carburante.

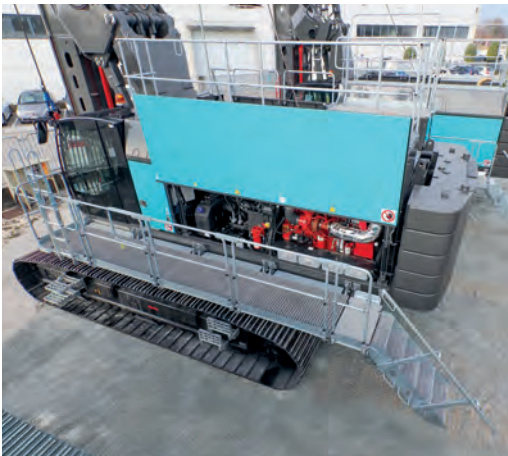

SAFETY AND MAINTENANCE

Hydraulic lifting canopy over the engine for easy access during inspections and maintenance. Optional stairs, platforms and railings provide safe accessibility to every point. Also, optional cameras and display for full visibility of the winches and working area.

SICUREZZA E MANUTENZIONE

La carrozzeria ad apertura idraulica permette rapido accesso durante ispezioni e manutenzioni. In opzione, scale, pedane e parapetti permettono accesso ad ogni punto di intervento e videocamere forniscono completa visibilità degli argani e dell'area di lavoro.



ENVIRONMENT AWARENESS

Rigs are powered by the latest generation Stage V diesel engine with reduced exhaust emissions and use of low sulfuric content fuels. Further reduction of CO₂ emissions is achievable by using HVO plant-based fuels. Bio-oils of high efficiency and performance are available.

ATTENZIONE ALL'AMBIENTE

La potenza è fornita da motori diesel di ultima generazione Stage V con ridotte emissioni inquinanti e si impiegano carburanti a basso tenore di zolfo. Ulteriore riduzione di emissione di CO₂ con l'uso di combustibili HVO di origine vegetale. Disponibili Bio-olii di elevata efficienza e prestazione.

CASAGRANDE HYDRAULIC PILING RIGS RANGE
GAMMA ATTREZZATURA IDRAULICA PER PALI CASAGRANDE



B125 XP2



B160 XP2



B175 XP2

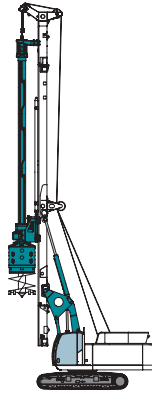

B200 XP2

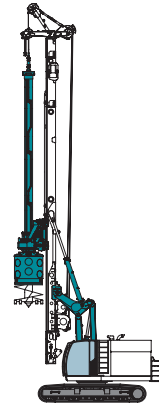

B240 XP2

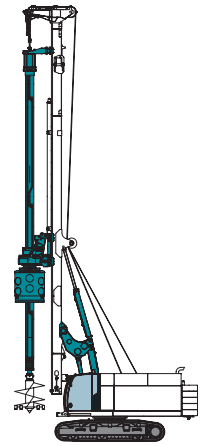

B250 XP2

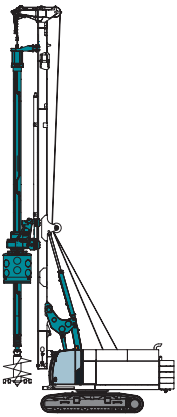

B275 XP2

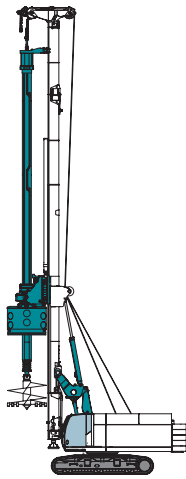

B300 XP2

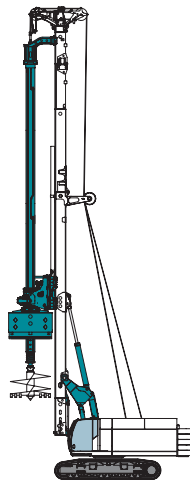

B360 XP2

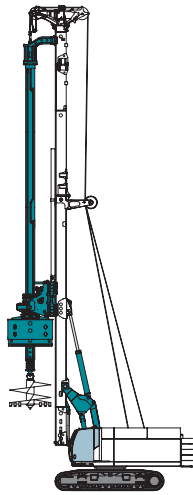

B400 XP2

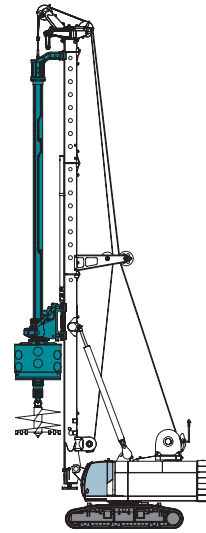

B420 XP2

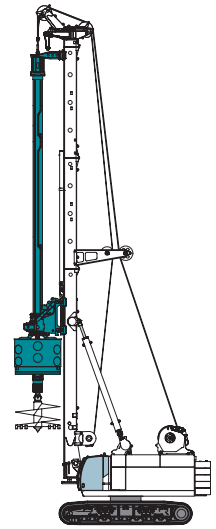

B470 XP2



CASAGRANDE S.P.A.

Via A. Malignani, 1
 33074 Fontanafredda - Pordenone (Italy)

Tel. +39 0434 9941
 Fax +39 0434 997009



info@casagrandegroup.com
 www.casagrandegroup.com