

C8 **XP-2**

HYDRAULIC CRAWLER DRILL
PERFORATRICE IDRAULICA



TECHNICAL INFORMATION

The Casagrande C8XP-2 is a hydraulic drill rig ideal for the projects in the field of foundation and is suited for constructing anchors, micropiles and jet grouting. Designed and built using the latest state of the of art technology. A machine engineered for the most demanding conditions with particular emphasis on performance efficiency, reliability and economy.

INFORMAZIONI TECNICHE

La Casagrande C8XP-2 è una perforatrice idraulica ideale per l'esecuzione di opere di consolidamento e perforazione mediante la realizzazione di ancoraggi, micropali e jet grouting. Progettata e costruita utilizzando le più recenti tecnologie. Una macchina ingegnerizzata per le condizioni di lavoro più impegnative, con particolare attenzione all'efficienza delle prestazioni, all'affidabilità e ai consumi.

1 "EP" ROTARY HEAD WITH ELECTRO-PROPORTIONAL CONTROL OF DISPLACEMENT

It is possible to define different settings to the requirement of the job site or the operator's requests

2 HEAVY DUTY MODULAR MAST

Extraction force 87 kN, stroke of single rotary head 10 m

3 MAST SUPPORT WITH STURDY STRUCTURE

Continuous movements +/- 93° without stops and without manual operation

4 CLAMP UNIT TYPE M4-M4S

Clamping force 283 kN - diameter 30 ÷ 305 mm

5 HD UNDERCARRIAGE WITH 360° SLEWRING

Long and wide tracks for low bearing pressure and high stability

6 POWERFUL DIESEL ENGINE

Power 209 kW at 2000 rpm

7 SPM - SMART POWER MANAGEMENT SYSTEM

Full load sensing hydraulic

1 TESTA DI PERFORAZIONE CON CONTROLLO "EP" ELETTRO-PROPORZIONALE DELLA CILINDRATA

È possibile definire differenti settaggi in funzione delle necessità del cantiere e delle richieste dell'operatore

2 MAST RINFORZATO MODULARE

Forza di estrazione di 87 kN, 10 m di corsa testa singola

3 SUPPORTO MAST MODULARE HEAVY DUTY

Ampia movimentazione +/-93° senza interruzione e senza intervento manuale

4 MORSE TIPO M4-M4S

Forza di chiusura 283 kN - diametro 30 ÷ 305 mm

5 SOTTOCARRO HD CON RALLA GIREVOLE 360°

Cingoli estesi per un'elevata stabilità e ridotta pressione al suolo

6 POTENTE MOTORE DIESEL

Potenza 209 kW a 2000 rpm

7 SPM - SMART POWER MANAGEMENT SYSTEM

Impianto idraulico full load sensing

C8^{XP-2}

PERFORMANCE - PRESTAZIONI



209 kW

Diesel engine power / Potenza motore



ELECTRIC MOTOR - Option
MOTORE ELETTRICO - Opzione



25000 kg

Operating weight / Peso attrezzatura



2500 mm @ 360°

Undercarriage / Sottocarro

Maximum values vary according to the set-up
I valori massimali variano in funzione dell'allestimento



TECHNICAL SPECIFICATIONS

DATI TECNICI

DIESEL ENGINE		MOTORE DIESEL				
Diesel engine Stage V - Tier 4		Motore diesel Stage V - Tier 4		CUMMINS B 6.7		
Power @ 2200 rpm		Potenza @ 2200 rpm		209 kW		
Diesel tank capacity		Capacità serbatoio gasolio		400 l		
Urea tank capacity		Capacità serbatoio urea		57 l		
* Diesel engine Stage IIIA - Tier 3 equivalent		Motore diesel Stage IIIA - Tier 3 equivalente		CUMMINS QSB 6.7		
Power @ 2200 rpm		Potenza @ 2200 rpm		201 kW		
HYDRAULIC SYSTEM		IMPIANTO IDRAULICO				
Hydraulic power		Potenza idraulica		170 kW		
Hydraulic pressure		Pressione idraulica		350 bar		
Main pump flow rate		Pompa principale portata		1 x 424 l/min		
Option main pump flow rate		Portata pompa principale opzionale		1 x 134 l/min		
Hydraulic oil tank capacity		Capacità serbatoio olio idraulico		630 l		
UNDERCARRIAGE		SOTTOCARRO		B2		
Undercarriage width		Larghezza sottocarro		2500 mm		
Width of triple grouser track shoes		Larghezza pattini a tre barre		600 mm		
Overall tracks length		Lunghezza cingoli		3560 mm		
Travel speed		Velocità traslazione		0 - 2,2 km/h		
Traction force - nominal		Forza di trazione - nominale		270 kN		
MAST		MAST		12000 MR	10000 MR	
Mast length		Lunghezza mast		12000 mm	10000 mm	
Stroke of rotary head		Corsa testa di rotazione		10000 mm	8000 mm	
Extraction / Crowd force		Forza di Estrazione / Spinta		87 kN (100)*	87 kN (100)*	
Extraction / Crowd speed		Velocità di Estrazione / Spinta		56 (81)* m/min	56 (81)* m/min	
CLAMPS	MORSE	M2Z M2SZ	M4 M4S	M5 M5S	M6 M6S	M7 M7S
Diameter	Diametro	32 ÷ 254 mm	30 ÷ 305 mm	76 ÷ 406 mm	101 ÷ 508 mm	76 ÷ 610 mm
Clamping force	Forza di chiusura	159 kN	283 kN	283 kN	283 kN	283 kN
ROTARY HEAD	TESTA DI ROTAZIONE	T 20 EP	T 2500 EP	T 3000 EP	T 5000 EP	
Max. torque	Coppia max.	15200 Nm	22200 Nm	30000 Nm	70000 Nm	
Max. speed	Giri max.	400 rpm	226 rpm	160 rpm	50 rpm	

* Option
Opzione

DIMENSIONS

DIMENSIONI

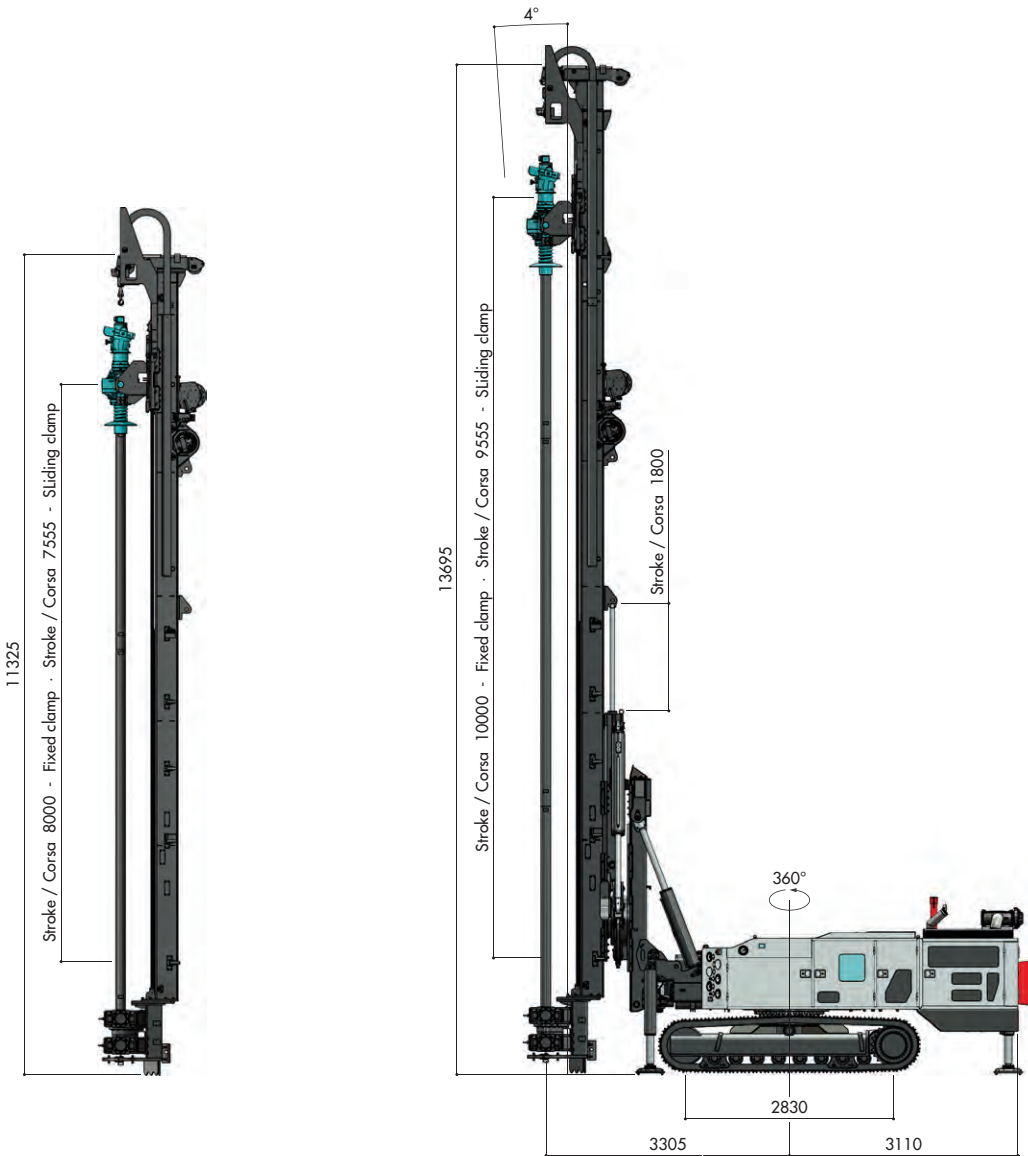

TRANSPORT DATA

DATI DI TRASPORTO

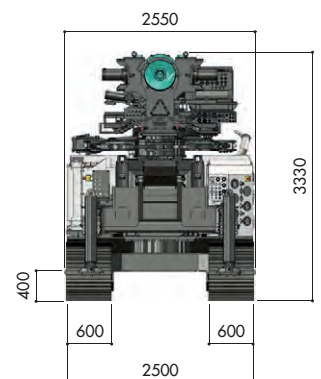
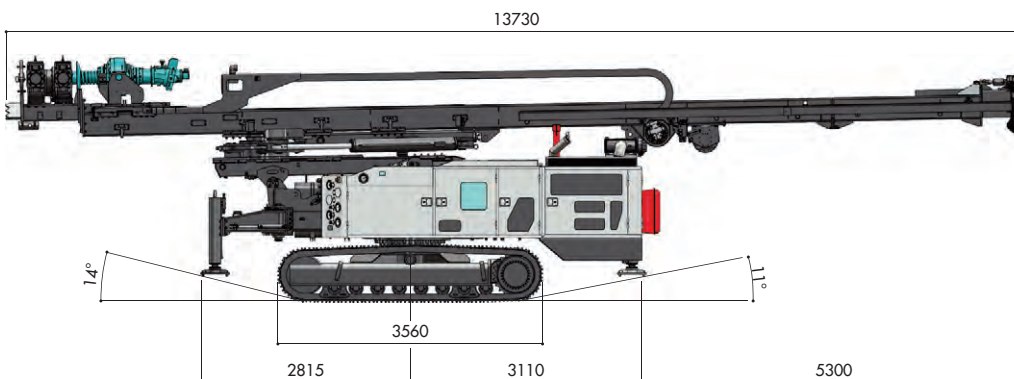

Weight of rig (depending of mounted equipment)
 Peso attrezzatura (dipende dall'allestimento montato)
~25000 kg

MAST MOVEMENTS

MOVIMENTAZIONI MAST

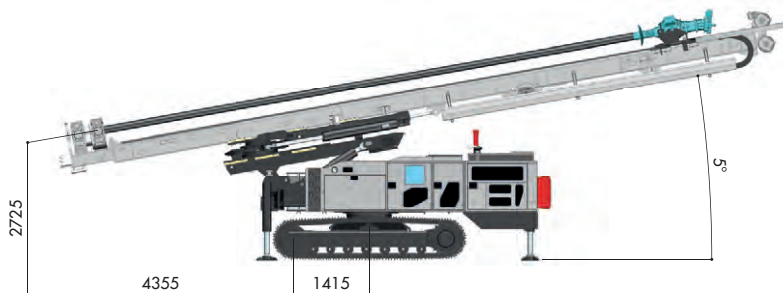
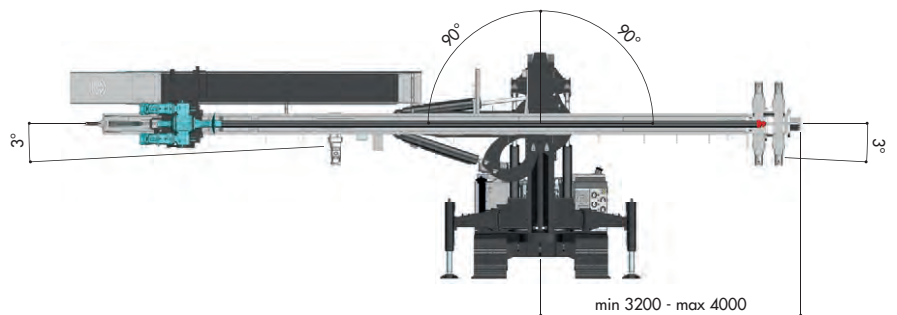
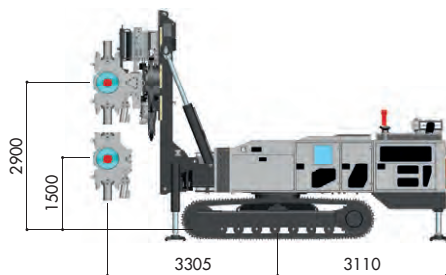
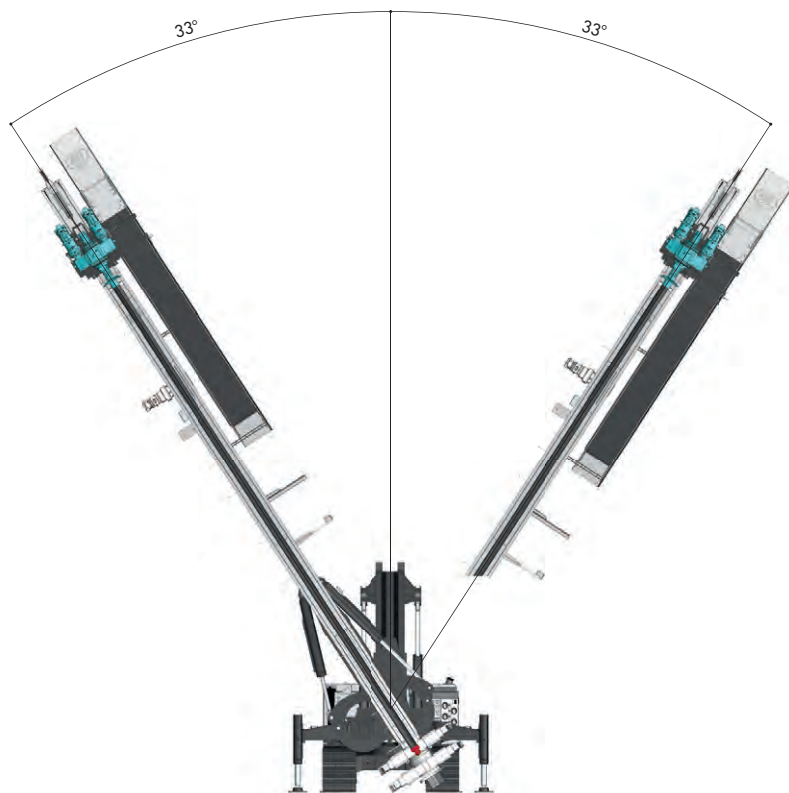

Rig movements are the maximum allowable. Any additional equipment on the rig may limit these movements.
 Movimentazioni massime consentite. Differenti allestimenti della perforatrice possono limitare queste movimentazioni.

DOUBLE ROTARY HEAD ARRANGEMENT

ALLESTIMENTO CON DOPPIA TESTA

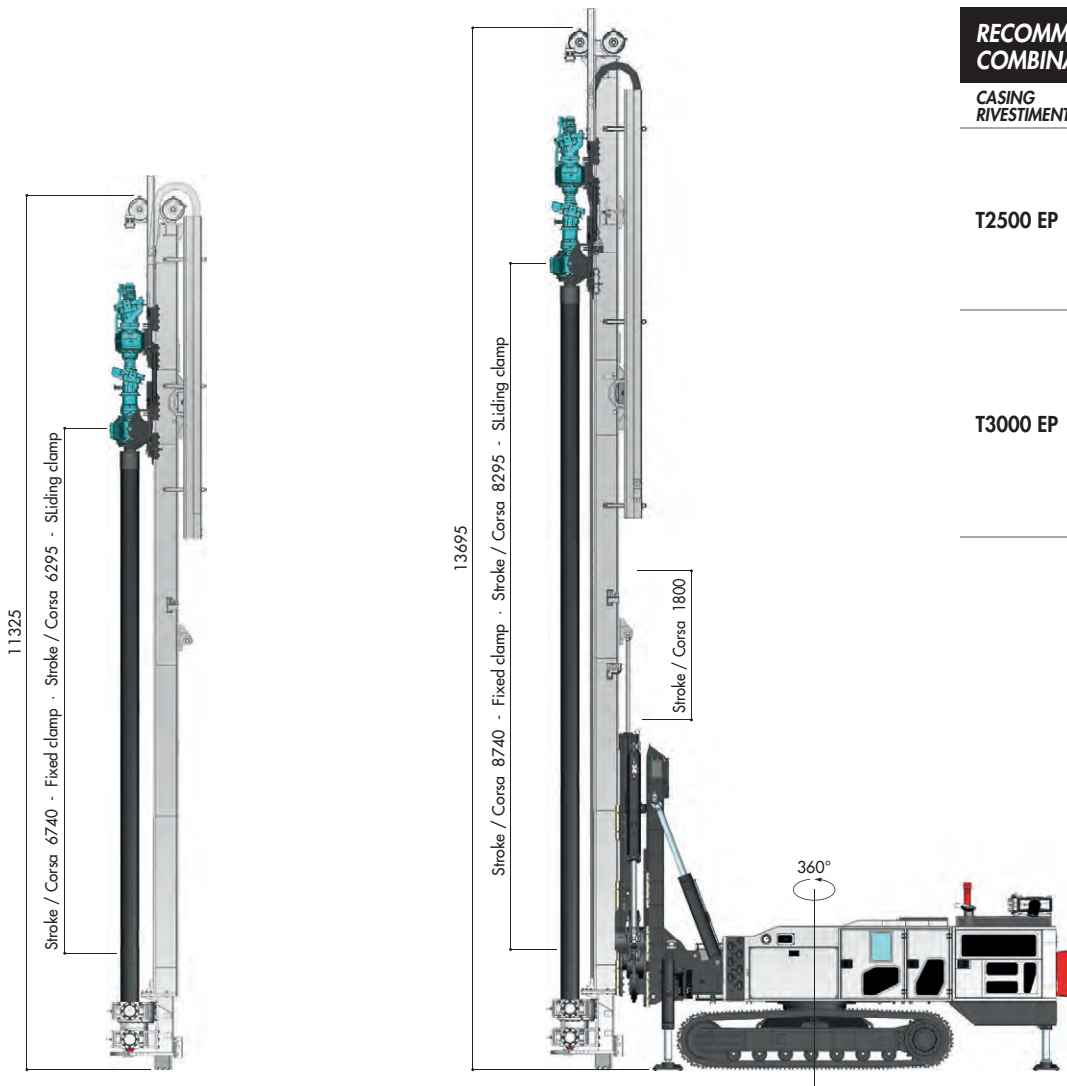

RECOMMENDED DOUBLE ROTARY HEAD COMBINAZIONI DOPPIA TESTA

CASING RIVESTIMENTO	RODS ASTE
T2500 EP	T14 EP
	T20 EP
	T16X
	T24X
T3000 EP	T20 EP
	T16X
	T2500 EP
	T24X
	T32X

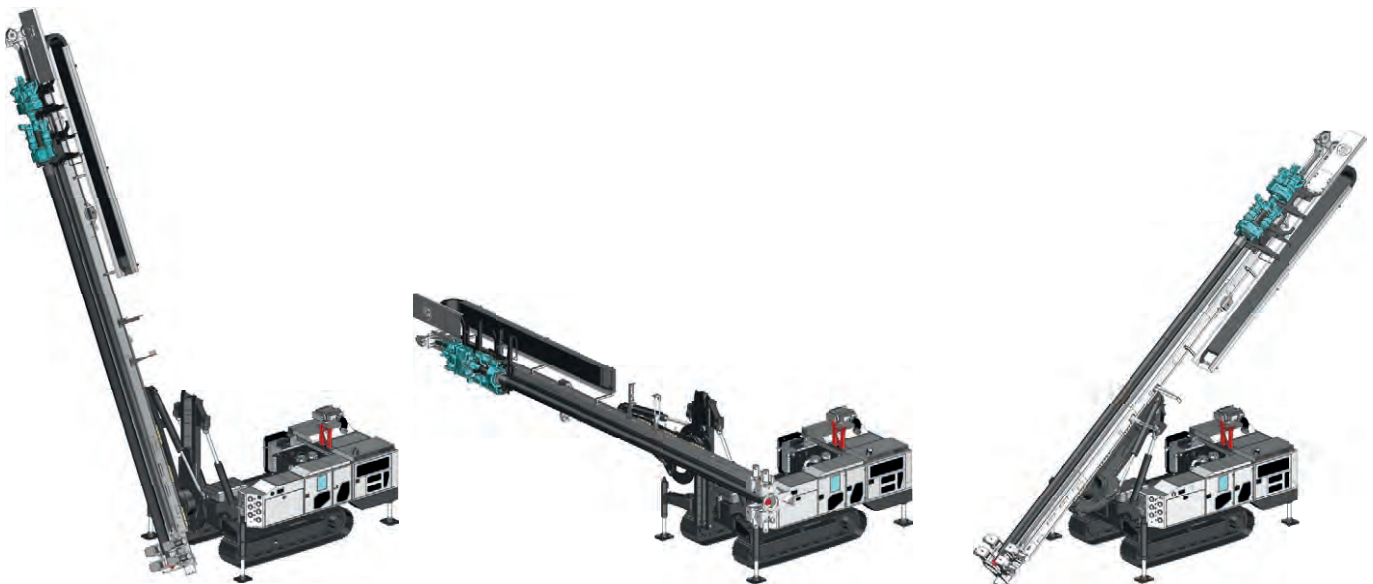

JET GROUTING ARRANGEMENT

ALLESTIMENTO JET GROUTING

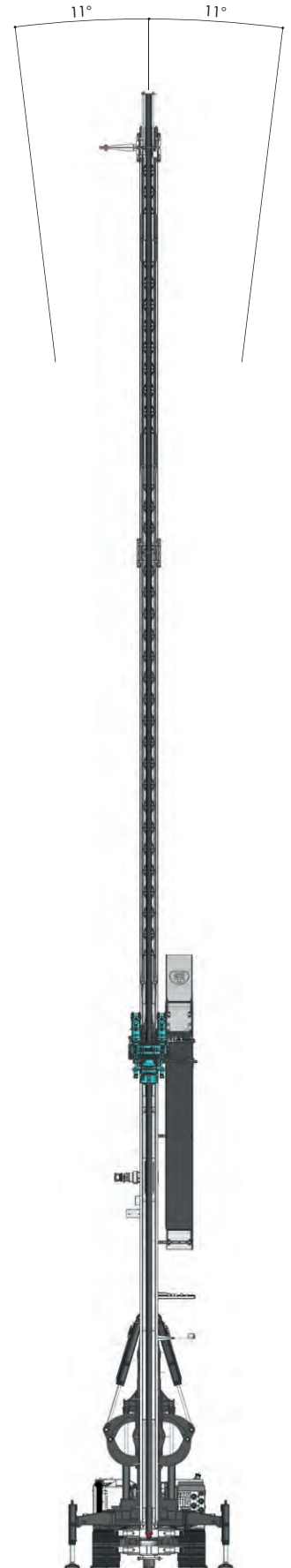
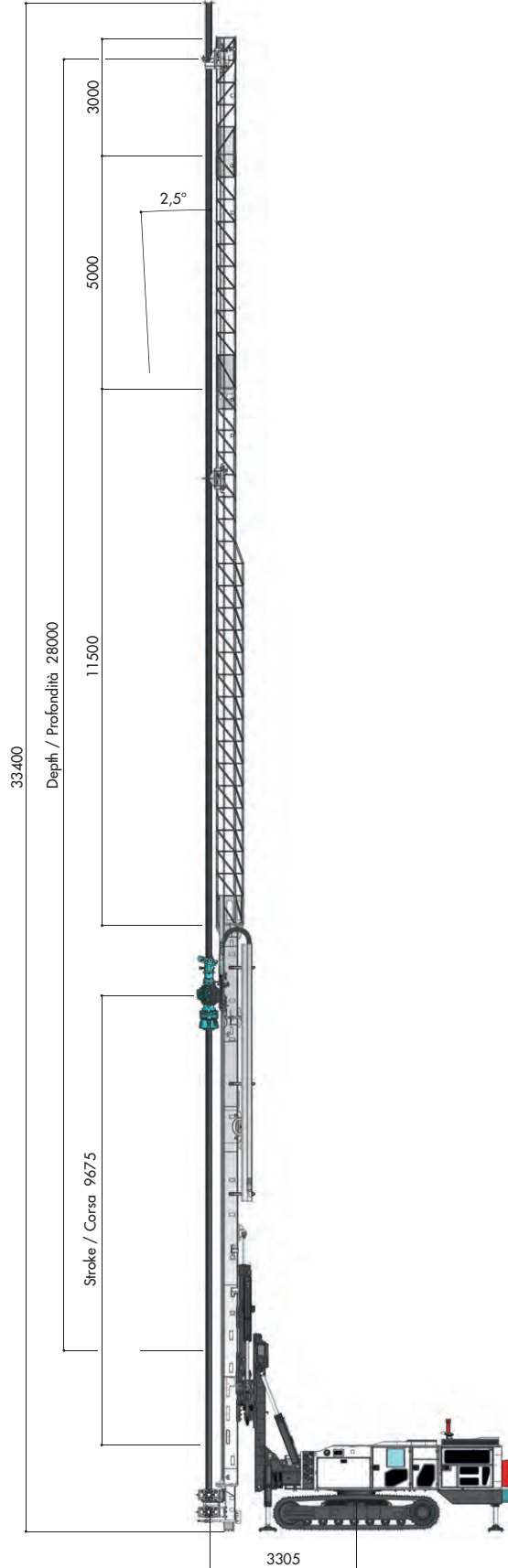
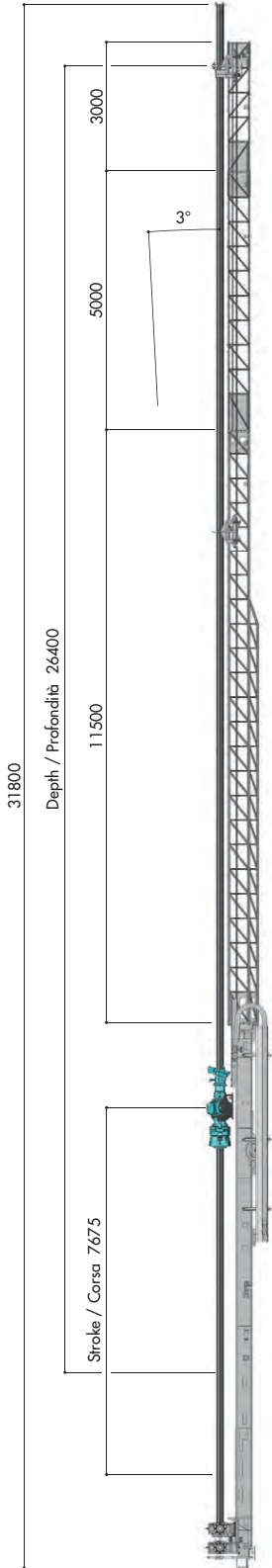

C8V KINEMATICS TYPE VERTICAL

C8V ARTICOLAZIONE TIPO VERTICALE



TRANSPORT DATA

DATI DI TRASPORTO

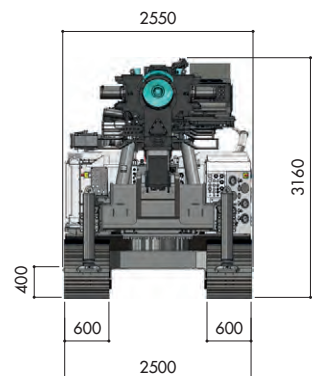
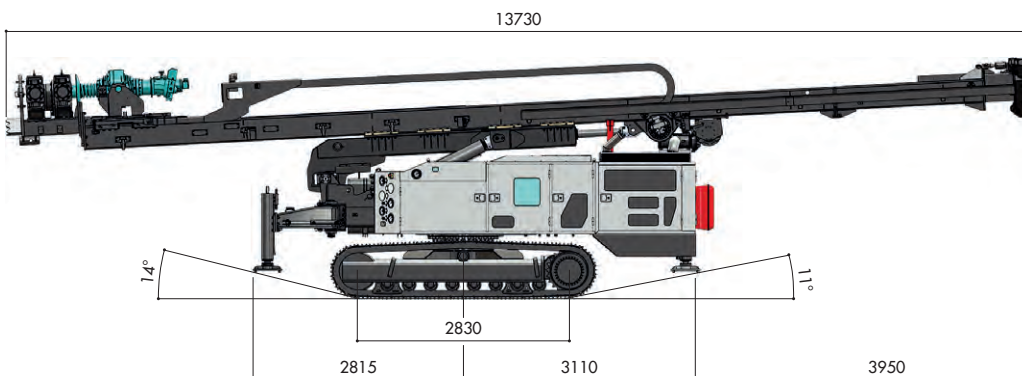

OPTIONS

OPZIONI

BASIC MACHINE

Electric motor 132 kW

Other rotary heads available

Drifter type T40 for T14EP and T20EP

Drifter type T50 for T2500EP

Rotopercussion unit T16X - T24X - T32X

Auxiliary winch with rope - Max line pull 2000 kg - 3000 kg

Cathead for auxiliary winch

Self-pivot pulley Cathead with self-pivoting pulley for auxiliary winch

Telescopic and swinging cat head

Auxiliary crane

Jet grouting system

Super jet grouting arrangement

Hydraulic chuck type P114 - P200 for jet grouting rods

Lubricator for down-the-hole hammer 8,5 l - 20 l

Manual centralized greasing system

Remote control or radio remote control for tracking and positioning

Safeguards according to EN 16228

CDR - Casagrande Data Recording system for working parameters and recording

Casagrande FleetMaster remote rig control and monitoring via internet

MACCHINA BASE

Motore Elettrico 132 kW

Altre teste di perforazione disponibili

Applicazione martello T40 per T14EP e T20EP

Applicazione martello T50 per T2500EP

Testa rotopercolazione T16X - T24X - T32X

Argano ausiliario con fune - Tiro max. 2000 kg - 3000 kg

Falchetto per argano ausiliario

Falchetto con carrucola orientabile per argano ausiliario

Falchetto telescopico rotante

Gru di servizio

Impianto per jet grouting

Allestimento super jet grouting

Mandrino idraulico P114 - P200 per aste jet grouting

Oliatore per applicazione martello fondo foro 8,5 l - 20 l

Impianto di ingrassaggio manuale centralizzato

Radiocomando o filo comando per traslazione e posizionamento

Protezioni di sicurezza secondo EN 16228

Sistema CDR - Casagrande Data Recording per monitoraggio e registrazione parametri di lavoro

Casagrande FleetMaster monitoraggio e controllo delle macchine via internet

OPTIONS

OPZIONI

BASIC MACHINE

Flushing pump - Water pump
GAMMA 62 (60 l/min max - 50 bar max)
GAMMA 202 (200 l/min max - 60 bar max)

Pump CC30/20S
Foam: (30 l/min max - 50 bar max)
High pressure: (30 l/min max - 200 bar max)

Mud pump
NG530 L (215 l/min - 24 bar) | NG600 L (310 l/min - 24 bar)
NG800 L (480 l/min - 20 bar) | NG1200 L (960 l/min - 14 bar)

Mud and slurry pump:
Triplex 90 (90 l/min max - 45 bar max)
Triplex 200 (200 l/min max - 45 bar max)
Triplex 300 (300 l/min max - 35 bar max)

Water, mud and cement pump
STA T60 (600 l/min max - 40 bar max)

MACCHINA BASE

Pompa acqua
GAMMA 62 (60 l/min max - 50 bar max)
GAMMA 202 (200 l/min max - 60 bar max)

Pompa CC30/20S
Schiumogeni: (30 l/min max - 50 bar max)
Idropulitrice: (30 l/min max - 200 bar max)

Pompa fanghi
NG530 L (215 l/min - 24 bar) | NG600 L (310 l/min - 24 bar)
NG800 L (480 l/min - 20 bar) | NG1200 L (960 l/min - 14 bar)

Pompa fanghi e cemento:
Triplex 90 (90 l/min max - 45 bar max)
Triplex 200 (200 l/min max - 45 bar max)
Triplex 300 (300 l/min max - 35 bar max)

Pompa acqua, fanghi e cemento
STA T60 (600 l/min max - 40 bar max)



OPTIONS

OPZIONI

RC7 LOADER FOR RODS AND CASINGS#	CARICATORE RC7 PER ASTE E RIVESTIMENTI#		BRC133	BRC152	BRC178	BRC219
Diameter of casings	Diametro rivestimenti	mm	133	152,4*	177,8*	219,1*
Diameter of rods	Diametro aste	mm	88,9	101,6*	114,3*	133*
Length of casings and rods	Lunghezza aste e rivestimenti	mm	3000	3000	3000	3000
Number of rods and casings	Numero aste e rivestimenti	nr.	7 + 7	7 + 7	6 + 6	5 + 5
Length of rods only	Lunghezza solo aste	mm	4500	4500	4500	4500
Number of rods	Numero aste	nr.	7 + 7	7 + 7	7 + 7	7 + 7
Max. diameter of rods	Diametro max. aste	mm	133	152,4	177,8	219,1
Weight of loader	Peso caricatore	kg	1070	1070	1070	1070
Max. weight of rods and casings	Peso max. aste e rivestimenti	kg	1000	1000	1000	1000

* With special inserts kit / Con kit inserti speciali

R10 CAROUSEL	CARICATORE R10		RODS WITH BLOCK TEETH ASTE CON DENTE DI BLOCCO		WITH LOCKING CLAMP CON MORSA PER ASTE	
Max. rods length	Lunghezza max. aste	m	6000	6000	7000	8000
Capacity	Capacità	Rods	10	5	6	6
		Ø mm	76 ÷ 114	114 ÷ 140	76 ÷ 140	76 ÷ 140
Weight of rods loader	Peso caricatore	kg	1150	1150	1150	1150
Max. weight of rods	Peso max. aste	kg	1270	1270	1270	1270
Max. depth (mast 10000)	Profondità max. (mast 10000)	m	68 (60+8)	38 (30+8)	50 (42+8)	-
Max. depth (mast 12000)#	Profondità max. (mast 12000)#	m	70 (60+10)	40 (30+10)	52 (42+10)	58 (48+10)

R8 CAROUSEL	CARICATORE R8						
Max. rods length	Lunghezza max. aste	m	6000	6000	6000	6000	6000
Capacity	Capacità	Rods	8	10	12	14	16
		Ø mm	140÷152,4	114÷133	101,6	88,9	76,1
Weight of rods loader	Peso caricatore	kg	1200	1200	1200	1200	1200
Max. weight of rods	Peso max. aste	kg	1200	1200	1200	1200	1200
Max. depth (mast 10000)	Profondità max. (mast 10000)	m	56 (48+8)	68 (60+8)	80 (72+8)	92 (84+8)	104 (96+8)
Max. depth (mast 12000)#	Profondità max. (mast 12000)#	m	58 (48+10)	70 (60+10)	82 (72+10)	94 (84+10)	106 (96+10)

2 RODS LOADER	CARICATORE 2 ASTE		MAST 10000	MAST 12000#
Max. rods length	Lunghezza max. aste	m	6500	8500
Capacity 2 rods	Capacità 2 aste	Ø mm	76 ÷ 168	76 ÷ 168
Capacity 1 rod	Capacità 1 asta	Ø mm	168 ÷ 219	168 ÷ 219
Weight of rods loader	Peso caricatore	kg	630	630
Max. weight of rods	Peso max. aste	kg	760	760
Max. depth	Profondità max.	m	21 (13+8)	27 (17+10)
Option: trolley for anchoring operation	Opzione: carrello per lavori di ancoraggio			

SLIDING CLAMP	MORSA SCORREVOLE		M5-M5S/C	M6-M6S/C
Diameter	Diametro	mm	76 ÷ 406	76 ÷ 508
Clamping force	Forza di chiusura	kN	283	283
Torque	Coppia	kNm	46	70
Extraction stroke	Corsa di estrazione	mm	1000	1000
Extraction force	Forza di estrazione	kN	200	250
Weight	Peso	kg	1650	1780

With additional counterweight / Con zavorra addizionale

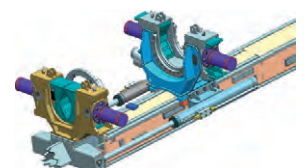
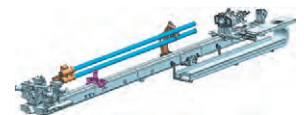
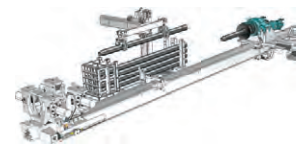
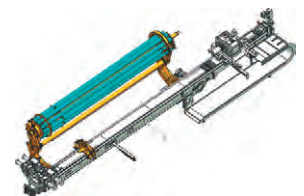
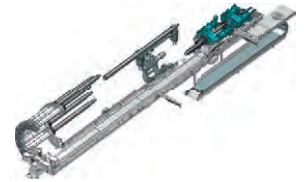

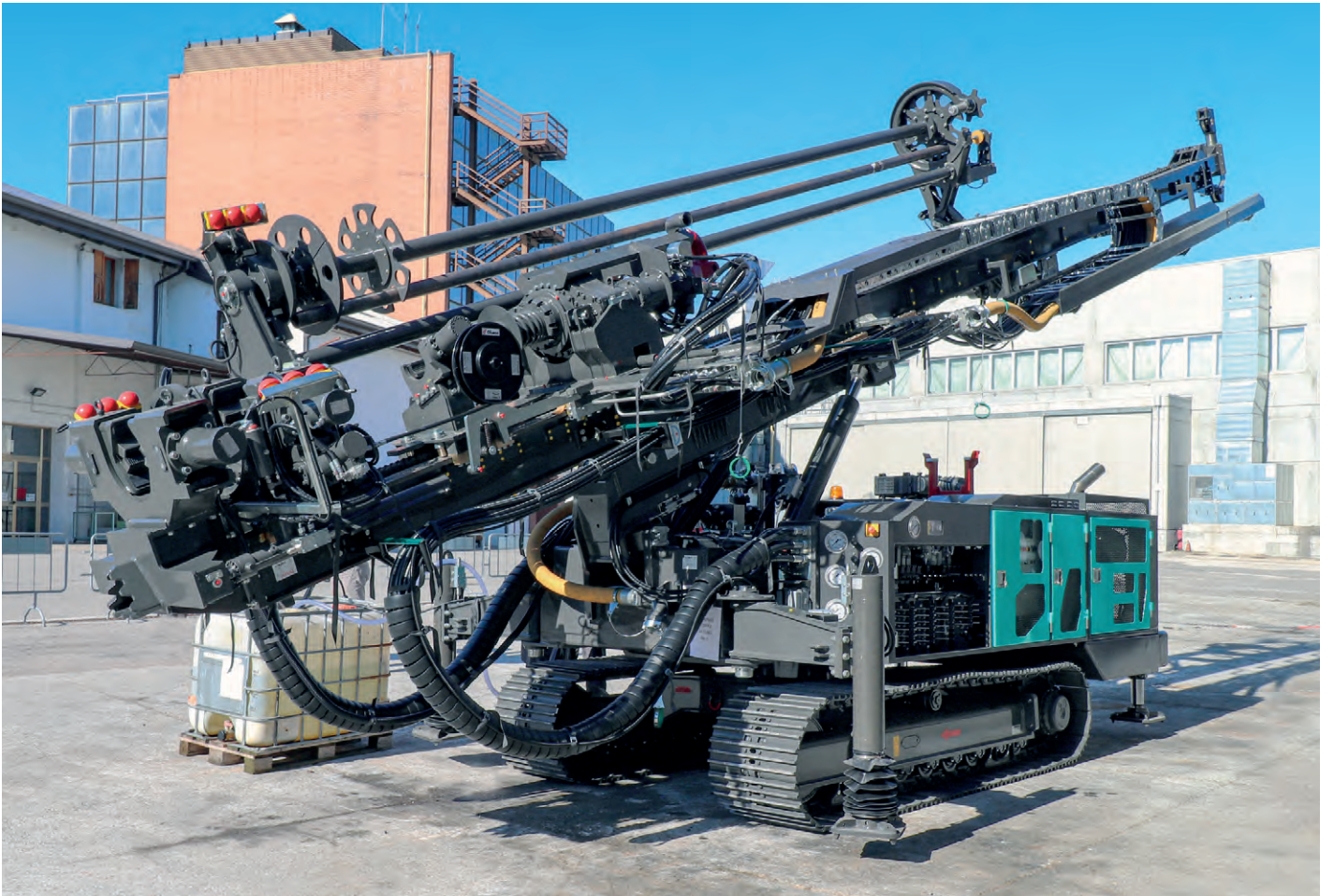

EXPERIENCE, PLUS, INNOVATION

ESPERIENZA E INNOVAZIONE

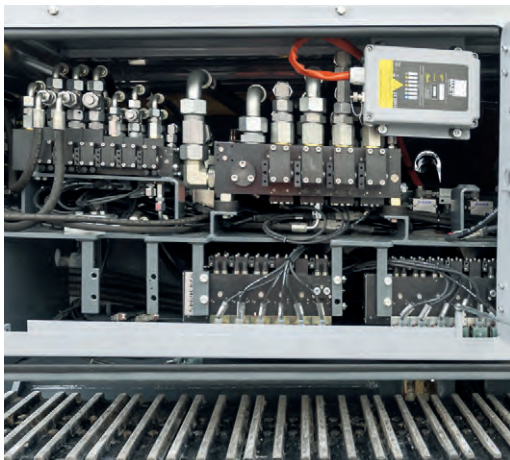

XP-2 SERIES

The XP-2 series use hydraulic and electronic systems that control the hydraulic pumps to achieve efficient, precise and rapid results. The specialist components, along with the enhanced hydraulic layout, optimizes efficiency leading to reduced load losses and fuel consumption.

XP-2 SERIE

Gli impianti idraulici delle macchine serie XP-2, sono realizzati per un controllo in load sensing delle pompe idrauliche e del circuito di potenza, per una efficiente, precisa e rapida esecuzione delle manovre. L'impianto idraulico e i componenti sono ottimizzati per ridurre le perdite di carico e per una maggiore efficienza.



CFM - CASAGRANDE FLEET MASTER

The fleet can be managed remotely via an online platform by PC, tablet or smartphone. This includes remote monitoring of any alarms and immediate diagnostics by the After Sales Service Team leading to significant reductions in intervention costs and rig downtime.

CFM - CASAGRANDE FLEET MASTER

È la piattaforma online che permette di controllare lo stato della flotta macchine da web remoto con PC, tablet o smartphone. Monitoraggio di eventuali allarmi e immediata diagnostica da parte dell'assistenza con riduzione di costi di intervento e tempi di fermo macchina.



ASSISTANCE AND MONITORING

Operators benefit from automatisation of drilling functions, making the rigs user friendly with complete control of the drilling process. The display on board provides real time drilling data progress including rotary head oil pressure, speed, drilling depth and verticality for operator control.

ASSISTENZA E MONITORAGGIO

Il compito dell'operatore è semplificato grazie alla disponibilità di automatismi che semplificano il lavoro ed ottimizzano i risultati. Sistemi di monitoraggio delle funzioni di lavoro forniscono in tempo reale ed efficace all'operatore il controllo delle operazioni.

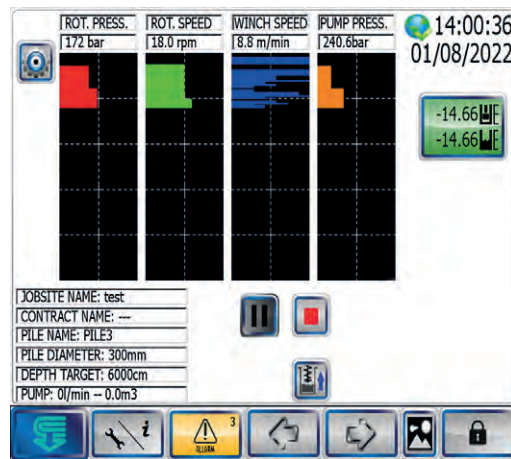

CDR - CASAGRANDE DATA RECORDER

CDR is available for all disciplines of piling and drilling and allows the rig operator to monitor the drilling progress on screen. Work parameters are recorded for subsequent analysis, or for site reports.

CDR - CASAGRANDE DATA RECORDER

Il CDR è applicabile per le macchine Casagrande ed è disponibile per tutte le tecnologie di lavoro. L'operatore monitora sullo schermo l'andamento del processo e i parametri delle lavorazioni sono registrati per successive analisi o per redazione di report di cantiere.

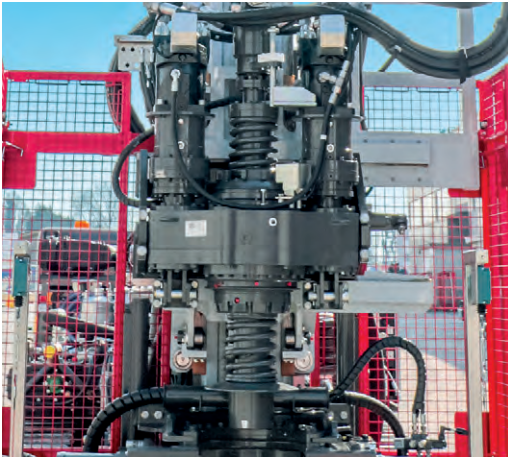

PERFORMANCE AND PRODUCTIVITY

The Smart Power Management (SPM) is an engine power management system that improves performances and productivity of the machinery. SPM monitors the power flows drawn from the engine and allocates the maximum available power to the required function.

PRESTAZIONI E PRODUTTIVITÀ

Il sistema Smart Power Management (SPM) permette una gestione intelligente della potenza del motore, aumentando prestazioni e produttività. Esso monitora i flussi di potenza istantanei e destina in tempo reale la piena potenza disponibile alle funzioni di lavoro.



COMFORT & TECHNOLOGY

The radio remote control is ergonomically designed with reduced weight and dimensions for user comfort. Latest technology for reduced response time and more effective operations. Smart oil heat exchangers reduce fuel consumption and the overall noise level of the cooling system.

COMFORT & TECHNOLOGY

Radiocomando è progettato secondo criteri ergonomici di dimensioni e pesi per il comfort dell'operatore. Tempi di reazione minimi e aumento dell'efficacia delle operazioni grazie alla tecnologia impiegata. Scambiatori di calore smart riducono il livello di rumorosità e il consumo di carburante.



SAFETY AND MAINTENANCE

The layout of the machine and the wide openings of the canopy offer comfortable and easy access for inspection and maintenance. The machine conforms to the last international standards to guarantee the maximum safety of the operations.

SICUREZZA E MANUTENZIONE

L'intelligente disposizione dei componenti e le ampie aperture della carrozzeria offrono comodo e sicuro accesso per tutte le operazioni di ispezione e manutenzione. La sicurezza delle operazioni di lavoro è garantita dal rispetto dei più stringenti standard internazionali.



ENVIRONMENT AWARENESS

Rigs are powered by the latest generation Stage V diesel engine with reduced exhaust emissions and use of low sulfuric content fuels. Further reduction of CO₂ emissions is achievable by using HVO plant-based fuels. Bio-oils of high efficiency and performance are available.

ATTENZIONE ALL'AMBIENTE

La potenza è fornita da motori diesel di ultima generazione Stage V con ridotte emissioni inquinanti e si impiegano carburanti a basso tenore di zolfo. Ulteriore riduzione di emissione di CO₂ con l'uso di combustibili HVO di origine vegetale. Disponibili Bio-oli di elevata efficienza e prestazione.

CASAGRANDE HYDRAULIC CRAWLER DRILLS RANGE
GAMMA PERFORATRICI IDRAULICHE CASAGRANDE



C3 XP2



C4 XP2



C5R XP2



C5 XP2



C6 XP2

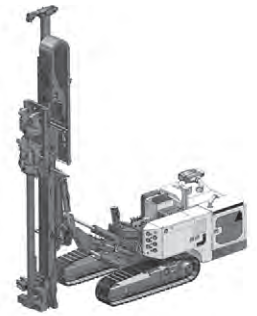

M9 XP2



C7 XP2



C8 XP2



C9 XP2



C10 XP2



C12 XP2



C16 XP2



CASAGRANDE S.P.A.

Via A. Malignani, 1
33074 Fontanafredda - Pordenone (Italy)

Tel. +39 0434 9941
Fax +39 0434 997009



info@casagrandegroup.com
www.casagrandegroup.com